



# Perry County Design Guidelines

Draft August 11, 2022



COMMUNITY  
**DESIGN**  
SOLUTIONS

MAHAN RYKIEL  
ASSOCIATES INC

# Perry County, PA Design Guidelines

Prepared for  
Perry County, Pennsylvania

Funded by  
Keystone Communities Grant



**MAHAN RYKIEL**  
LANDSCAPE ARCHITECTURE  
URBAN DESIGN & PLANNING

## Table of Contents

<b>1. INTRODUCTION</b>	<b>5</b>
Purpose and Goals .....	6
<b>2. SITE DESIGN</b>	<b>11</b>
Building Setback/Alignment .....	12
Street Orientation .....	14
Parking .....	16
Streetscaping & Landscape .....	19
Alleys / Rears of Buildings .....	23
Fences, Walls, & Railings .....	26
<b>3. EXISTING COMMERCIAL BUILDINGS</b>	<b>29</b>
Preservation of Traditional Facade Elements .....	31
Removal of Inconsistent Elements .....	32
Storefront Renovation & Replacement .....	33
Window Renovation & Replacement .....	36
Door Renovation & Replacement .....	38
Awning Renovation & Replacement .....	40
Painting .....	41
Repair & Cleaning .....	44
Replacement of Unavailable Components .....	45
Additions to Existing Structures .....	46
Demolitions & Relocations .....	47

## **4. NEW COMMERCIAL BUILDINGS 49**

Building Heights .....	50
Façade Proportion & Rhythm .....	51
Alignment of Architectural Elements.....	53
Roofs and Upper Story Details .....	54
Wall Materials.....	56
Piers/Building Frame.....	57
Doors & Windows .....	58
Storefront.....	60
Awnings & Canopies.....	61
Balconies .....	62
Color of Materials.....	65
Foundations.....	66
Exterior Materials.....	67
Roofs.....	72
Gutters & Downspouts .....	73
Chimneys.....	74
Porches & Entry Stoops .....	75
Entrances & Doors.....	76
Windows & Storm Windows .....	77
Details .....	81
Code Compliance .....	82
Additions .....	83

## **5. NEW RESIDENTIAL BUILDINGS 85**

New Buildings.....	86
Context & Basic Character.....	87
Site Design .....	88

## **6. MISCELLANEOUS GUIDELINES 89**

Artwork .....	90
Signs.....	93
Automobile-Oriented Uses.....	100

## **7. DESIGN REVIEW CHECKLISTS 101**

Checklist .....	102
-----------------	-----

## **8. APPENDICES 109**

Architectural, Design & Planning Terms .....	110
Acknowledgments & Sources.....	114

---

Page left blank intentionally to accommodate double-sided printing.



# Introduction

PERRY COUNTY DESIGN GUIDELINES

## Purpose and Goals

The overall intent of the design guidelines and associated design review process is to ensure that new construction and proposed alterations to existing properties will enhance—rather than adversely affect—the architectural character of Perry County. The intent is two-fold and is the same regardless of whether the application concerns an existing property or a proposal for new construction. First, the guidelines provide the owners of downtown properties assistance in making decisions about maintenance, improvements, or architecturally sensitive design within the existing context of the borough in which they are located. Second, they provide the Perry County Economic Development Authority (PCEDA) and each borough's leadership with a framework for objective evaluation of proposed improvements or designs. These guidelines reflect the PCEDA's philosophy that underlies its decisions: to encourage the preservation and careful treatment of the county's buildings and historically significant resources while recognizing the need for continuing adaptation and improvements to these resources, and to encourage the introduction of new architectural assets.

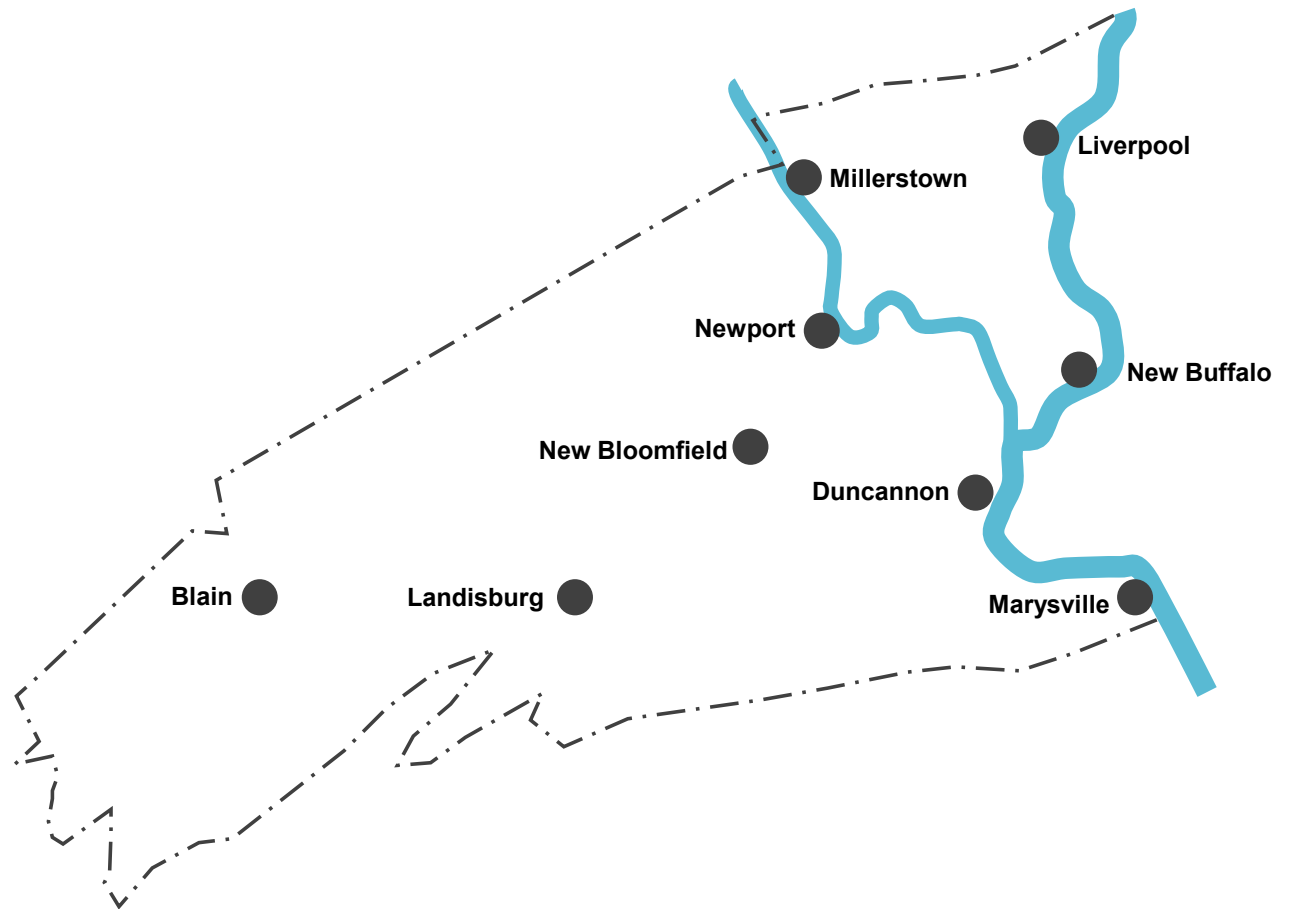

Figure 1.1.1. Perry County

---

## WHO DO THE DESIGN GUIDELINES SERVE?

The design guidelines are a companion document to the Perry County Economic Vitality Plan completed in 2021 for the PCEDA, particularly the Facade Improvements Best Practices and The Architectural Design Studies chapters. The Architectural Design Studies chapter, in particular, illustrates before and after examples of how the design guidelines outlined on the following pages can be applied to specific Perry County buildings.

The guidelines serve several audiences:

- » Primarily they are designed to assist commercial property and business owners in seeking façade and/or property improvement grants administered by the PCEDA and/or borough leadership.
- » They serve as a general guideline for commercial property/business owners who are interested in improving their property or constructing a new building/addition regardless of whether or not they are seeking grant funding.
- » Many of Perry County's downtown businesses are located within adapted residential structures and some boroughs' downtowns are comprised mostly of residential structures. Because the guidelines address those specific residential architectural characteristics, they may be useful to property owners and homeowners who are interested in making improvements to a residential property.
- » Finally, they serve as a guide to PCEDA and the boroughs' leadership in the decision-making process for administering grant funding (if grant funding is being sought).

## DOCUMENT FLEXIBILITY

The guidelines provide information to property owners about maintenance, repair, rehabilitation and historic and/or distinctive characteristics of the buildings in Perry County. The standards in the design guidelines are not rigid. Instead, they are to be used as guiding principles in preserving the character and integrity of properties in Perry County, while encouraging profitable business activities.

Included are a variety of ways to design exterior renovations or new construction in the downtown area. These guidelines will assist in maintaining the character of the downtown. They will also allow for individuality and architectural creativity.

Property owners are encouraged to consult a licensed architect and Perry County/borough departments to ensure that exterior rehabilitation, improvements or new construction are appropriate for the building and surrounding properties.

The design guidelines also address many components of a property that influence its aesthetic appeal (site, streetscape, fencing, parking, etc.) and are not limited to the building alone. Additionally, grant funding may be available from time to time to assist property owners in making improvements to their properties or specific components of their properties. Grant funding may not always be available, however, and grants can vary greatly in terms of award amounts, restrictions on the use of the funding, time limitations, etc. Therefore, the document is designed to be as broad as possible; but in many cases, only certain chapters may be relevant for a specific funding-cycle. For example, a particular grant may stipulate that only improvements to a building (not a site) can be eligible for a grant. Another grant may stipulate that

only commercial-not residential-properties are eligible. For property owners seeking grant funding, it will be important to check with the PCEDA and/or borough leadership to understand current eligibility and restrictions.

## DESIGN REVIEW PROCESS

The PCEDA has established an Architectural Review Board (ARB) to review applications from property owners who are seeking grant funding. The composition of the ARB and the design review process may change from time to time. That information will be provided by the PCEDA with each grant application cycle.

The PCEDA has also adopted the Secretary of the Interior's Standards for Rehabilitation (see call out box) as the basis for guidance on rehabilitation design for historic properties. These standards represent strict requirements for properties with a historic designation and must be adhered to if a property owner is making modifications to a locally designated historic structure or structure within a local historic district. They must also be adhered to if a property owner is seeking tax incentives for a structure located within a national historic district. Otherwise, these standards provide a solid reference for anyone wanting to make improvements to a property regardless of whether it is historically designated or located within an historic district.

The design guidelines outlined on the following pages expand the Secretary of Interior's Standards and bring focus to Perry County's own unique context and re-sources, providing guidance for historic and non-historic structures.

---

## SECRETARY OF INTERIOR'S STANDARDS FOR REHABILITATION

1. A property shall be used for its historic purpose or be placed in a new use that requires minimal change to the defining characteristics of the building and its site and environment.
2. The historic character of a property shall be retained and preserved. The removal of historic materials or alteration of features and spaces that characterize a property shall be avoided.
3. Each property shall be recognized as a physical record of its time, place, and use. Changes that create a false sense of historical development, such as adding conjectural features or architectural elements from other buildings, shall not be undertaken.
4. Most properties change over time; those changes that have acquired historic significance in their own right shall be retained and preserved.
5. Distinctive features, finishes, and construction techniques or examples of craftsmanship that characterize a property shall be preserved.
6. Deteriorated historic features shall be repaired rather than replaced. Where the severity of deterioration requires replacement of a distinctive feature, the new feature shall match the old in design, color, texture, and other visual qualities and, where possible, materials. Replacement of missing features shall be substantiated by documentary, physical, or pictorial evidence.
7. Chemical or physical treatments, such as sandblasting, that cause damage to historic materials shall not be used. The surface cleaning of structures, if appropriate, shall be undertaken using the gentlest means possible.
8. Significant archeological resources affected by a project shall be protected and preserved. If such resources must be disturbed, mitigation measures shall be undertaken.
9. New additions, exterior alterations, or related new construction shall not destroy historic materials that characterize the property. The new work shall be differentiated from the old and shall be compatible with the massing, size, scale, and architectural features to protect the historic integrity of the property and its environment.
10. New additions and adjacent or related new construction shall be undertaken in such a manner that if removed in the future, the essential form and integrity of the historic property and its environment would be unimpaired.



# Historic Narrative

## COMMUNITY AND ARCHITECTURAL CHARACTER

### COMMUNITY CHARACTER

**Landform**-The Ridge-and-Valley Province of the Appalachian Mountains, comprised of folded bands of mountain ridges and long valleys.

**Agriculture**-Large tracts of agricultural lands are interspersed with compact and walkable communities with each borough.

**Market Squares**-Many boroughs are centered around historic market squares that still serve as activity centers. The squares are well-defined by architecture and consistent setbacks.

**Materials**-The use stone that is so prevalent in the natural environment is incorporated into buildings, walls, bridges, and other structures. Wood from surrounding forests is also a prevalent building material.

### ARCHITECTURAL CHARACTER

**Entry Stoops with Asymmetrical Placement**-Many buildings in the county are characterized by covered stoops placed on the building in an asymmetrical fashion.

**Bracketed Roof Overhangs**-Brackets, typically ornamental, are often used to support roof overhangs.

**Windows with Decorative Trim**-Windows are often highlighted by various trims, sometimes ornamental and highlighted with a contrasting color.

**Ornamental Balustrades**- Balustrades are often found along porch and stoop edges, often ornamental and highlighted with contrasting colors.

Perry County is located in central Pennsylvania and is a rural county with a population of 46,262 (2019). Established in 1820, Perry County retains a distinct rural character that is augmented by the Susquehanna and Juniata Rivers and the ridgelines of the Appalachian Mountains. The county is home to nine (9) Boroughs and thirty one (31) townships.

Perry County's rural location and topography places it in a unique position in central Pennsylvania. Its proximity to the Harrisburg metro creates a unique blend of rural character in the county itself and easy access to jobs, retail and dining, and other amenities found in urban areas.

The qualities that define Perry County's rural character are outlined in the Community Character and Architectural Character chapters of the Perry County Economic Vitality Plan. These are summarized in the call-out box to the right.

---

Page left blank intentionally to accommodate double-sided printing.



# Site Design

PERRY COUNTY DESIGN GUIDELINES

# Building Setback/ Alignment

Typically, zoning ordinances address building setback in terms of distance away from the street or property line. In the context of historic downtowns, most buildings were constructed prior to or in the early days of the automobile. Therefore, they were built immediately adjacent to the street and sidewalks on the property line to facilitate commerce. This is often called a zero setback line or “build-to” line. A continuous row of buildings along the build-to line is often referred to as a “street wall” which plays an important role in defining the edges of the street.

For new construction and infill development, the goal is to provide a place where the pedestrian continues to have priority. It is, therefore, important to maintain the existing build-to line and place the new building in line with the existing buildings, with parking and service areas located to the rear or sides of building. This allows for pedestrians to engage with the storefronts, window displays, outdoor dining areas, etc., all of which contribute to walkable downtowns.

Entrances may be set back beyond the front façade provided that structural elements, such as columns, pilasters, etc., align with the street setback of adjacent buildings.



“Street wall” effect created by a continuous wall of buildings along the same “build-to” line in Perry County’s traditional downtowns.

*Changes in setback often occur further from the center of downtown. Any new infill development should follow the same setback as adjacent structures.*



# Building Setback/ Alignment [continued]

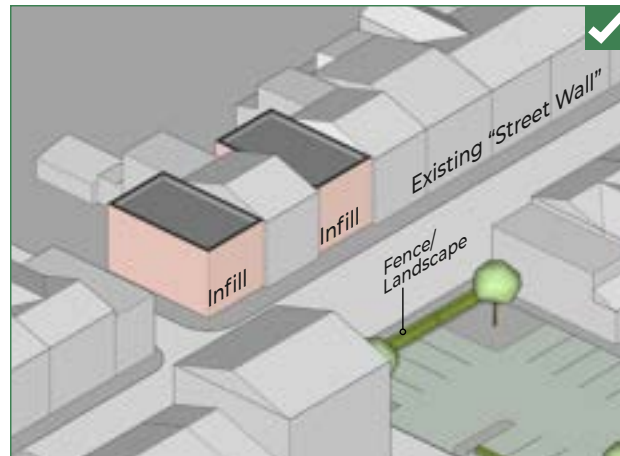
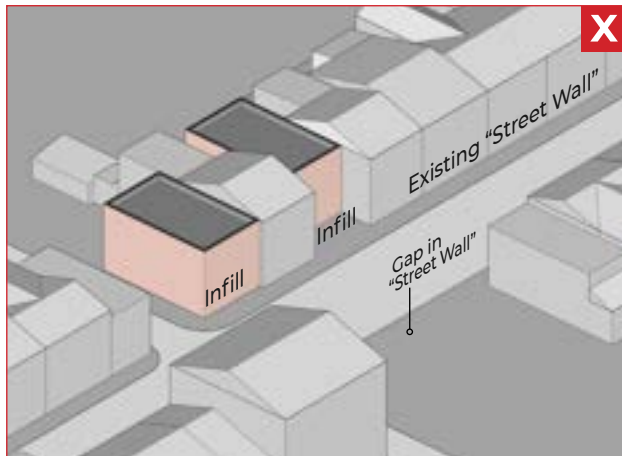

*Bad example of infill development that does not respond to the setbacks of either of the adjacent buildings.*

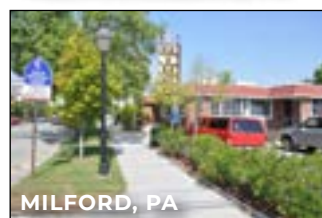

*Good examples of how architectural elements, fencing and landscape maintain the "street wall" where a building has been removed.*

## GUIDELINES

- » Buildings in the downtown district should work together to create a wall of buildings following the same build-to line, a characteristic associated with Perry County's traditional downtowns and borough centers and "Main Street" communities throughout the country.
- » New construction and infill buildings should maintain the alignment of façades along the sidewalk edge. Exceptions may be granted if the setback is pedestrian-oriented and contributes to the quality and character of the streetscape. An example would be for a park or outdoor dining space. Exceptions may also be granted for buildings whose functions are uniquely different from traditional downtown commercial buildings such as churches and stand-alone civic buildings.
- » In some Perry County communities, the build-to line steps back further from the street in the blocks farther out from the borough centers. For infill development in these locations, the new build-to line should be maintained.
- » In instances where a building has been removed from the street wall, consider utilizing other devices such as landscaping, sculpture, arches, walls, fencing, etc. to maintain the continuity of the "street wall" edge. There may also be opportunities to preserve the original building facade as a wall element.

# Street Orientation

The way that a structure is oriented to the street plays a large role in establishing the overall feeling of the street. As a general rule, buildings should be oriented so as to engage and maintain pedestrian interest.

Following are specific directions on how this can be accomplished.

## GUIDELINES

- » Storefronts should be designed to orient to the major street frontage and sidewalk. While side or rear entries are also encouraged, a predominant building entry should be oriented toward the primary pedestrian route.
- » In cases where the functional entry might be to the side or rear of the building (e.g., a hotel with a drop-off area to the side or rear of the building), a physical gesture of entry should still be considered along the major street frontage.
- » Buildings on corners should include entry design features that address both street frontages.



*New infill development should be oriented to the street edge with parking located behind.*



*Good example of rear entrance to a commercial building with primary entrance on the street side.*

## Street Orientation [continued]



*Good example of appropriate corner treatment for a corner building with two primary street frontages. The 45 degree corner allows the entry to address both streets equally.*



*Good examples of how building entrances respond to corner locations.*

# Parking

The automobile is a necessary part of contemporary life and the downtown environment and accommodating them is critical to how Perry County's boroughs function and to their economic viability. The priority in downtowns, however, is on creating a comfortable, safe, and appealing pedestrian environment. Therefore, accommodating automobiles should be handled differently here than in suburban settings where convenience is the priority.

## Surface Parking:

New surface parking lots should be located and designed to minimize the negative impact of large paved surfaces on the quality of the visual environment and to minimize gaps in active uses such as restaurants and storefronts.

- » Use ornamental fencing, low walls, trees, and/or low hedges along the parking lot edge adjacent to the street to continue the "street wall" defined by adjacent buildings.
- » Where possible, coordinate with adjacent property owners to consider connecting and reorganizing multiple inefficient adjacent surface parking lots into a single larger lot for greater efficiency. Use signage to identify spaces dedicated to specific businesses.
- » Use landscaping to visually enhance the edges of parking lots, provide shade on large expanses of pavement, and accommodate stormwater runoff.
- » Fencing
- » Rely upon wayfinding signage and parking lot signage to direct visitors to parking resources if they are not immediately visible



Good example of how a landscape hedge can minimize the visual impact of the large expanse of pavement associated with a gas station.

## GUIDELINES

- » Unless a building is beyond repair, avoid removing a building for the purpose of creating parking, especially on primary or "main" commercial streets.
- » Locate surface parking facilities on secondary blocks and streets where they best serve their function without jeopardizing the pedestrian quality of the downtown or the continuity of the "street wall" described earlier.
- » Strive to locate surface parking lots behind the buildings on primary commercial streets with access from side streets and alleys.
- » If necessary to have surface parking adjacent to a street edge, locate the parking at the interior of the block as opposed to corner locations. In downtown settings corner locations are important sites for prominent buildings. Parking lots on corners in the downtown area give the appearance of an incomplete block.

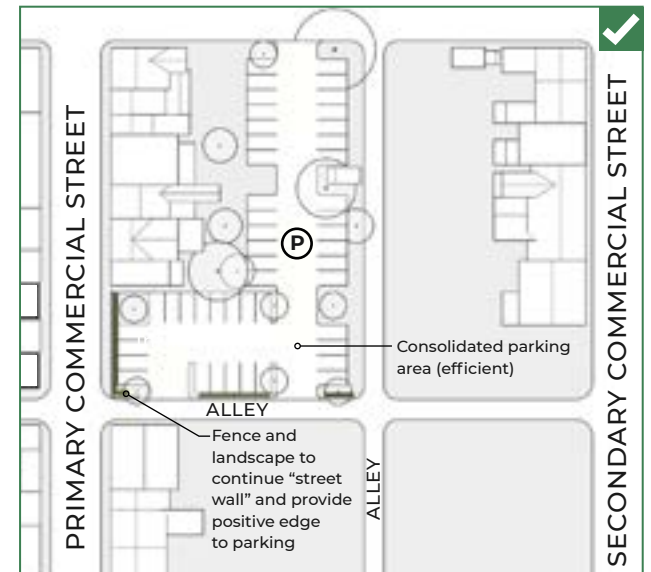
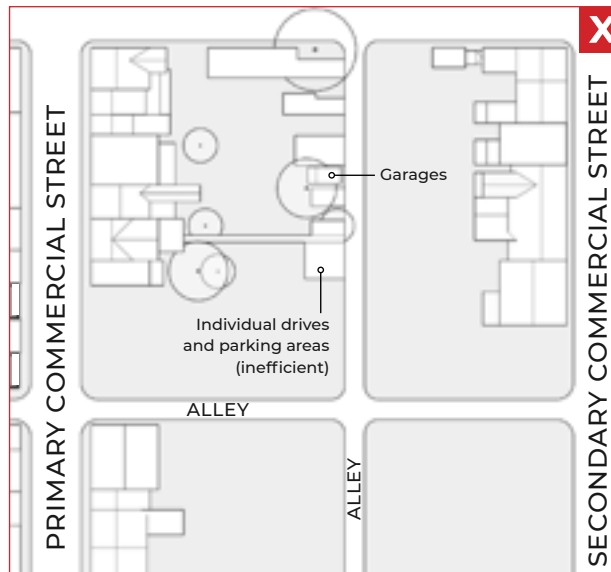



## Parking (continued)



*Good example of how preserving one existing tree can improve rear yard parking areas.*



*Good examples of how trees, hedges, and small landscape islands can improve surface parking lots*



*Good example of a fence and street trees providing a positive edge*

---

# Parking (continued)

## Structured Parking:

The need for structured parking in Perry County may be unlikely, however, there may be a time when some of the larger boroughs consider constructing it to allow for more economic development potential within the downtown areas.

Some of the important elements to consider in evaluating the design of parking structures include building massing, height, scale, and setback to adjacent buildings; the location of the facility within the downtown; and its security, landscaping, and lighting. It is important to construct attractive parking facilities that are compatible additions to downtown which add to, rather than detract from, the area's architectural character and function.

### GUIDELINES

- » Where possible, locate parking structures behind buildings on primary commercial streets or along secondary streets.
- » For parking structures with frontage along an important street edge, utilize a facade treatment that is compatible and complementary to adjacent building facades and consider ground floor retail uses to enhance the pedestrian experience.
- » Utilize natural topography to allow access to upper and lower levels of the parking structure without requiring internal ramping.



# Streetscaping & Landscape



**NEW BLOOMFIELD**

*Good example of how tall canopy trees enhance the streetscape and pedestrian experience while not obstructing views to storefronts.*



*Good example of a flow through planter to filter rainwater in an attractive manner.*



*Good example of how different elements—trees, signage, color, plantings, and storefronts contribute to a positive streetscape for pedestrians.*

The overall character of Perry County's downtown districts is defined by more than the buildings. Streetscape features such as street trees, planting strips between the sidewalk and the curb, paving, planter pots, lighting, street furniture, all contribute to community character and one's comfort and experience in a downtown. Similarly, the treatment of landscaped areas beyond the streetscape (such as "front yards" for former residential buildings converted to commercial uses, larger setback areas and building courtyards) are equally important.

## GUIDELINES

- » Preserve existing street trees or other site trees whenever possible.
- » When a tree must be removed, or when a new tree is being planted, utilize canopy shade trees that preserves—rather than blocks—sightlines to storefronts (beneath the mature canopy).
- » Consider planting to provide pops of seasonal color, even if the planting areas are small and narrow.
- » Consider use of planter pots and hanging baskets to provide seasonal color.
- » Where possible, incorporate pollinator plants into the landscape mix to provide ecological benefits.
- » Provide outdoor tables for dining and utilize colorful umbrellas that provide shade while also animating the streetscape.
- » For any landscaped areas along a primary commercial streets, maintain open sightlines by using low plantings (3' high maximum) and canopy trees with trees limbed up to a minimum of 8' from the ground.
- » Incorporate stormwater management where possible in the form of rain gardens and flow-through planters, particularly adjacent to large paved areas.
- » Where parking is directly off of the street, continue sidewalk paving across parking lot apron to give priority to the pedestrian.

# Streetscaping & Landscape [continued]



*Good example of how outdoor dining and umbrella tables can activate a streetscape.*



*Good example of how the sidewalk treatment can extend across a parking lot apron to prioritize the pedestrian.*

## Streetscaping & Landscape [continued]

*Good examples of how seasonal planting can enhance a downtown site, even if a narrow planting bed or small planter pot.*



# Streetscaping & Landscape [continued]



*Good examples of how seasonal planting can enhance a downtown site..*



## Alleys / Rears of Buildings



Good example of screening service equipment and trash bins utilizing wood gates with wrought iron ornament.

The alleys in Perry County's downtowns were historically used for secondary access to the buildings, for deliveries, and as storage places for horses and buggies, and later, for cars. While downtown alleys have evolved, they can create interesting secondary pedestrian systems to navigate downtown areas and may also provide an alternate means of access to shops, restaurants and other commercial uses.

### GUIDELINES

Where intact, alley façades should be preserved along with original features and materials. Alterations should be sensitive to and compatible with the scale and character of the building and area.



Examples of appropriate alley treatments such as pavers and sidewalks and fencing that meet the needs of both pedestrians and automobiles.

Care should be taken to create attractive rear facades and entrances, often with simply complementary paint color.

Ideally, rear entrances should serve as secondary entrances to maintain pedestrian activity along the primary streets and at primary building entrances.

Maintain and enhance existing original outbuildings and garages as they contribute positively to the community character and pedestrian experience.

When replacing (or building new) garage structures, utilize historic forms and roof pitches and, where possible, materials of similar structures.

Creative solutions (such as architectural screens, painting/public art and landscape) should be employed to conceal mechanical equipment, electrical service heads, etc.

- » Retain and preserve the variety and character found in the existing rear access to buildings along the alleys and/or streets.
- » Incorporate pedestrian-scaled street lighting and accent lighting to highlight rear building and alleyway entrances, outbuildings, facades, and other unique features. This is particularly important along alleyways that serve as important pedestrian connections between the primary commercial street and parking resources behind.
- » Where buildings are built to the alley edge, consider opportunities for alley display windows and secondary customer or employee entries, if original walls are not damaged.
- » Screening for service equipment, trash, or other rear-of-building elements that can be visually improved, should be designed as an integral part of the overall architectural design.

# Alleys / Rears of Buildings [continued]

*Perry County's alleys are characterized by pleasant lanes lined with outbuildings and garages. The top left image shows how, even though constructed out of concrete block, a relatively new garage maintains community character by using a pitched roof.*



**NEW BLOOMFIELD**



**NEW BLOOMFIELD**



**LIVERPOOL**

*Good examples of treating the rear and side facades of businesses and making them attractive to the community and customers.*



**BLAIN**



**LIVERPOOL**



## Alleys / Rears of Buildings [continued]



*Good example of how a green screen can buffer a service area from customers using a rear parking lot.*

HAVRE DE GRACE, MD

# Fences, Walls, & Railings

Fences, walls, and railings define the boundary between public and private areas and create safety barriers for pedestrians. Site specific design applications are encouraged that reflect Perry County's history, adjacent architecture, and/or public art.

## GUIDELINES:

Where visual privacy is not required for a private space, and where fencing is defining a public space, fence designs that reflect an open, transparent quality are encouraged. Visually closed-in fences that prohibit views into a public space are generally not appropriate.

- » For fencing, materials such as metal rails and posts, stone or brick piers, and wood may be used and should complement the materials of adjacent structures. A level of detailing or ornament used in the construction of the fences or railings is encouraged, provided it is compatible/complementary to adjacent buildings.
- » Where possible, historic wrought iron fencing should be preserved and repaired.

- » In general, metal surfaces should have a black or bronze finish although colors that are incorporated as part of a coordinated color plan for the building, or that are used characteristically throughout the downtown, may be considered.
- » Chain link fencing should be avoided. Where it must be used, black vinyl coated chain link should be used.
- » Temporary fences and railings that have a make-shift appearance should be avoided. Chains, ropes and unsupported railings are unacceptable materials.
- » Typically, no signage, advertising, goods or merchandise should be placed on the fencing.
- » For walls, brick, stone, finished concrete, and stucco are encouraged and should be compatible with adjacent buildings.
- » The wall design and detailing should be compatible with adjacent architecture.
- » A maximum height of walls should be 3-4' so as not to obscure sightlines.
- » Where taller walls are required, attention to materials and overall design becomes more important.
- » Use of down-lighting or "wall washes" is encouraged to create visual interest on walls.



Simple, yet elegant, wrought iron fence which defines the boundary between private and public property without hindering views to or from either.



Ornate wrought iron gate segregating an alley entryway from the public sidewalk.



While permissible in a residential area, this type of privacy fence is inappropriate for a downtown commercial area.

## Fences, Walls, & Railings (continued)

*Good examples in of how fences and wall elements define public and private spaces while allowing visibility between spaces. Note how the colors, materials, and ornamentation are compatible with the adjacent buildings.*



NEW BLOOMFIELD



NEW BLOOMFIELD



NEW BLOOMFIELD



MILLERSTOWN



CARLISLE, PA



MECHANICSBURG, PA

*Good examples of fence and wall elements that define public and private spaces while allowing visibility between spaces. Note that the fences and wall elements are more ornamental in response to the traditional adjacent architecture.*



MECHANICSBURG, PA

*Good example of a tall wall that uses the same materials of the adjacent building and provides more privacy while still including transparency through the gate.*



NEW CUMBERLAND, PA

*Good example of contemporary metal fence and landscape that defines public and private space while allowing visibility between spaces.*



# Existing Commercial Buildings

PERRY COUNTY DESIGN GUIDELINES

## Existing Commercial-Type Buildings

While it is acknowledged that changes to structures in the downtown district will occur over time, it is also a concern that these changes do not damage the historic building fabric and character of downtown. This character is precisely what makes Perry County unique and enhances real estate values in the downtown area. Inconsistent improvements will decrease the value of all downtown properties. A desired outcome of these guidelines is to safeguard the investment that both the private and public sector have made in Perry County. Preservation of the exteriors and storefronts of these buildings will continue their contribution to the unique architectural character of the downtown. Any building renovation or alteration, no matter the planned use, must retain the overall design integrity of the historic building by protecting the original features and materials and respecting the traditional design elements.

The renovation/restoration of older structures provides an excellent means of maintaining and reinforcing the architectural character of Perry County's traditional downtown and should be encouraged. Renovation and expansion not only increases property values in the area but also serves as an inspiration to other property owners and developers to make similar efforts.

When an existing structure is to be renovated or expanded, care should be taken to complete the work in a manner that respects the original design character of the structure. The appropriate design guidelines in this chapter are provided as an aid to owners whenever a structure is to be renovated or expanded.



BLAIN



NEWPORT



MILLERSTOWN

# Preservation of Traditional Façade Elements

## ELEMENTS OF THE TRADITIONAL FAÇADE

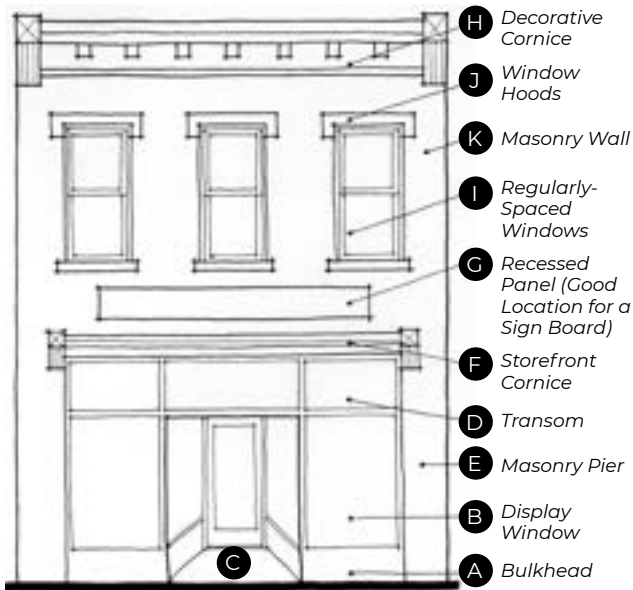

**P**reservation of traditional façade elements found on existing buildings creates patterns along the face of the block that contribute to the overall historic character of the area. These elements include:

- A. Bulkhead (or “kick plate”) as base to building fronts
- B. First floor display windows
- C. Recessed or covered central entrance areas or angled entrances on corners
- D. Transoms above entrance doors
- E. Masonry pier or building frame pilasters
- F. Storefront cornice
- G. Sign panel area
- H. Parapet walls with caps or cornices
- I. Vertical window patterns, shapes, window sills on second floor
- J. Window hoods (occasionally)
- K. Masonry wall

The façade elements define a building’s visual qualities and character. Respect the original design and materials of the building. Even when a building’s use has changed, it is still important to retain and/or interpret traditional façade elements.

Do not apply theme designs that alter the original character or architectural style such as coach lanterns (e.g., to make the building look more “Colonial”), mansard designs (e.g., to make the building look more “Victorian”), wood shakes (e.g., to make the building look more “Craftsman”), non-operable shutters, and small-pane windows if that is not the actual style of the building and/or they cannot be documented historically.

Preservation or restoration of ornamental details such as cast iron storefronts, pressed metal cornices, metal window hoods, and any other specialty ornament is particularly encouraged. Adding more elaborate ornamentation than was originally found on the building façade is typically inappropriate as it renders a false history to the building.

*Note: It is not the intention of this guideline to recreate the past if an original building façade does not exist. However, if the original façade had been modified over time, and documentary evidence such as photographs of the original features exist, then one recommended alternative is to restore the façade. Where exact reconstruction is not practical, new, contemporary interpretations of the original details are appropriate as long as the scale and character of the original detail is retained.*



## Removal of Inconsistent Elements

**R**etain original materials wherever possible through repair and restoration. Avoid concealing original façade materials. If the original material has been covered, uncover it if feasible. If portions of the original material must be replaced, use a material similar to the original. Avoid the use of materials that are not visually compatible with the original façade, such as shiny metals, mirrored glass, plastic panels, and vinyl windows or doors. (Note: Vinyl clad windows and doors may be allowed provided they are detailed in a manner that approximates the original design.)

Before (Carolina Furniture Building, Conway, SC)



After



[Left] The metal siding (or “slip cover”) conceals the architecture beneath and prevents alignment of architectural elements with adjacent buildings. Removal of metal slip covers is often inexpensive and produces dramatic results.

[Below] The choice of materials and composition at the storefront & upper façade level is visually incompatible with the traditional pattern of downtown commercial architecture. The historic architectural elements of the buildings are concealed. The absence of horizontal alignment of façade elements results in visual chaos.





# Storefront Renovation & Replacement

For most traditional buildings, large panes of glass at the display window level with solid kick plates below are appropriate. Multi-pane designs that divide the storefront window into small components should only be used if they restore proven historic elements and original openings.

## GUIDELINES

- » Maintain traditional recessed entries where they exist.
- » Maintain the original size, shape and proportion of storefronts and openings to retain the historic scale and character.
- » Maintain the bulkhead, or kick plate, below the storefront display window element.
- » Preserve the transom and sign board area features.

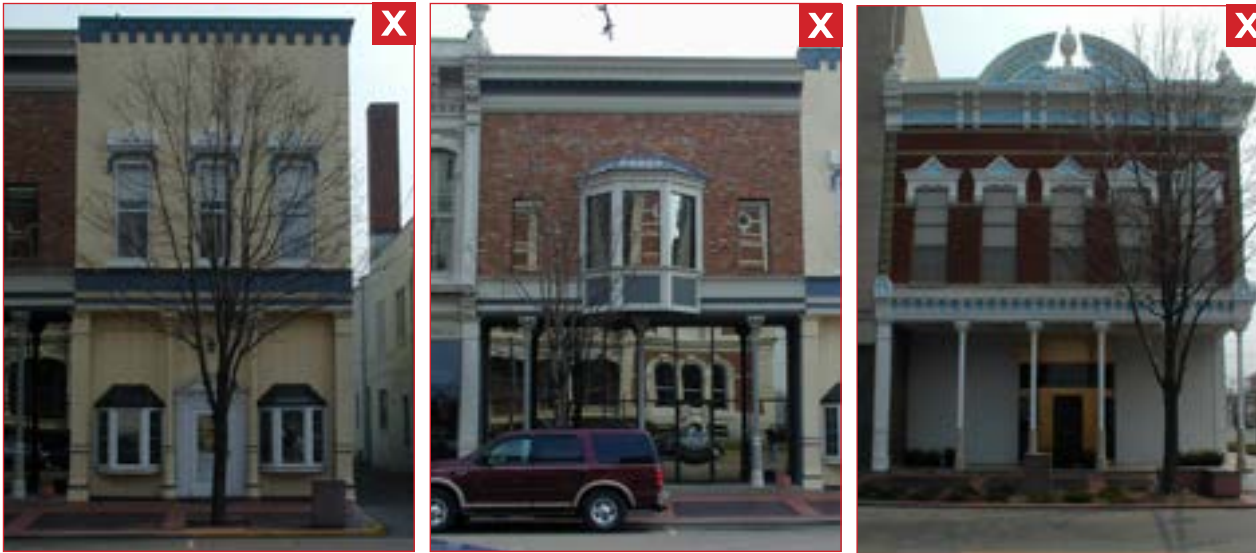

Examples of inappropriate storefront renovations & replacements.

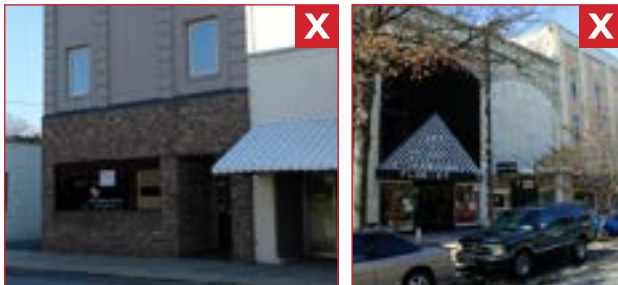

The transom area of these two storefront needs a transparent treatment to respond to the traditional storefront layout.



One way to deal with the transom area is to conceal it with an awning. All the other elements of the traditional storefront are dealt with appropriately in this example.



Good example of storefront renovation utilizing new materials adhering to traditional storefront composition.

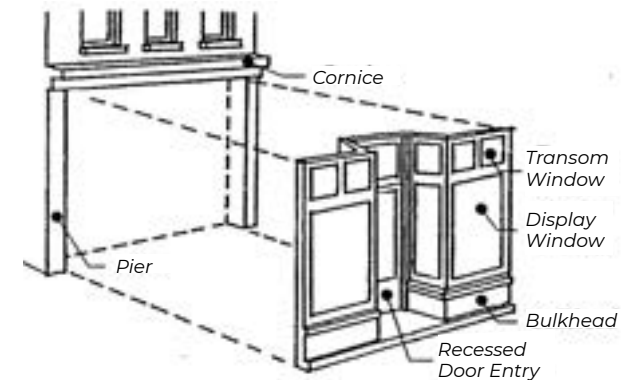

# Storefront Renovation & Replacement (continued)



*Bad example of use of smaller window that replaced original storefront windows.*

*Good examples that maintain recessed entries.*

## Storefront Renovation & Replacement (continued)

*Good examples of maintaining original size and proportions of storefronts.*



# Window Renovation & Replacement

**R**e-open or reveal upper story windows if they are presently covered. Maintain the original size and spacing of the windows. Preserve the window frame, sash, and surrounds. Repair rather than replace original windows whenever possible. If repair is not feasible, replace with windows that match the existing windows as closely as possible. Size, frame and trim material, method of operation, size of sash members, window frame elements, and the pattern of divided lights are important features to replicate.

## GUIDELINES

- » Whenever possible, repair, rather than replace existing windows.
- » If repair is not feasible, and the window must be replaced, match the existing window in terms of size, materials, method of operation and detailing.
- » The window opening itself should be carefully preserved. It should not be made larger or smaller to accommodate a differently sized window.



*Perry County has a rich tradition of historic windows with ornate trim and window hoods as seen in the four photos shown here.*



## Window Renovation & Replacement (continued)



*This arched-top window appropriately fills in the entire masonry opening.*



*In this example, the original arched-top windows were removed and rectangular units were installed in their place with a wooden "filler" inserted in the arched area. This gives the appearance of an "eye lid" closing above the windows. Always fill the opening with an appropriately sized window.*



*True divided light wood windows were the norm in traditional construction.*



*Historically, most windows installed during Perry County's primary period of downtown commercial development were 1-over-1, or 2-over-2 in pattern. However, installations such as the 6-over-1 pattern shown above were used successfully to introduce character and variety.*



*Tri-partite window provides visual interest.*



*The horizontal alignment of windows unifies these three buildings of dissimilar heights, colors and detailing.*

# Door Renovation & Replacement

Front doors and primary entrances are among the most important elements of traditional buildings. The original size and proportion of a front door, the details of the door, the door surround, and the placement of the door all contribute to the character of the entrance. Where possible, original doors and door hardware should be retained, repaired and refinished, provided they can comply with the requirements of the Americans with Disabilities Act (ADA). If new replacement doors are necessary, they should be compatible with the character and design of the structure itself and the downtown district as a whole.

## GUIDELINES

- » Maintain original doors whenever possible.
- » Repair damaged original doors and door assemblies whenever possible.
- » Retain and preserve the functional, proportional and decorative features of a primary entrance. These features include the door and its frame, sill, head, jamb, moldings, and any flanking windows.
- » If an original door must be replaced, the replacement door should match the original as closely as possible. If documentation of the original door is not available, then the appearance of the replacement door should be based on original doors on similar structures in the downtown area.
- » Doors in additions to existing structures should reflect the proportions (height and width) of doors in the existing structure and the district.



Successful "contemporary interpretation" of the traditional storefront door.

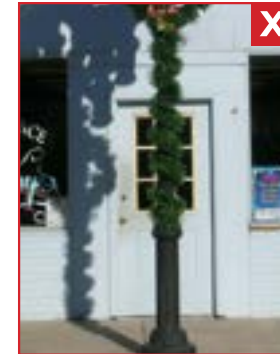

The style and detailing of this door is inappropriate to the building itself and the overall character of the district. The door utilizes a window and panel system that would have been associated with a "colonial" style building, not the Victorian/Commercial style of downtown Lake City.

## Door Renovation & Replacement (continued)



*The material, detailing, and lack of transparency in these doors are inappropriate replacement solutions.*

*Good examples of replacement doors responding to the traditional door treatment of historic commercial buildings.*

*Full-lite, wood doors, as shown in these two photos were traditionally used in downtown commercial districts. Contemporary materials and interpretations of this tradition are appropriate.*



# Awning Renovation & Replacement

Original awning hardware should be used if it is in working order or is repairable. The traditional canvas, slanted awnings are most appropriate for older storefronts and are encouraged. Replacement awnings should be designed to fit the storefront opening to emphasize the building's proportions. Awnings should not obscure or damage important architectural details. Awning color should be coordinated with the color scheme of the building. In general, solid color awnings should be used on buildings with intricate and abundant architectural detailing, while striped awnings might be utilized on simpler buildings to introduce color and vitality to an otherwise "plain" building.

## GUIDELINES

- » Awnings may be used to provide shade, color, and detail.
- » It is strongly preferred that awnings in the downtown commercial area not utilize vinyl nor be backlit.



LIVERPOOL

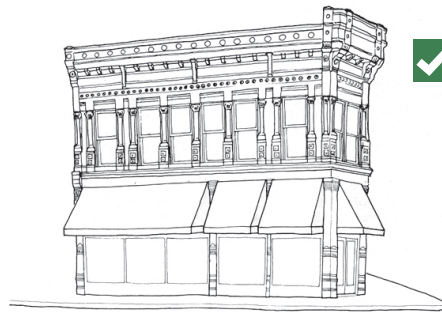
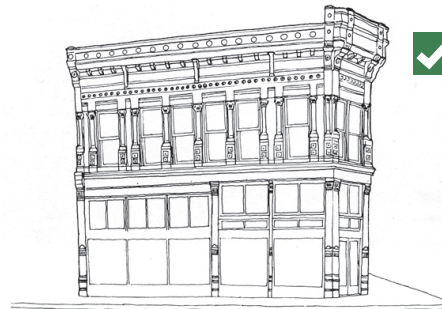
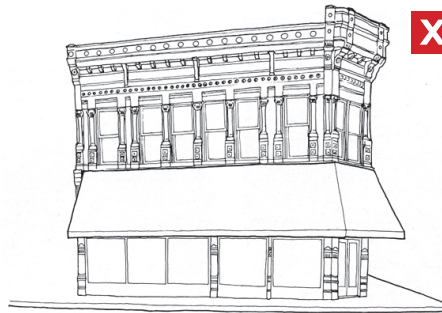

Illustrations depicting appropriate and inappropriate placement of awnings. Awnings at top do not respect the supporting frame of the building nor the corner entrance. Awnings at bottom fit within the building frame and break at the corner to highlight entry.



Perfectly executed awning installation.



Shingled canopy appears as oversized awning concealing transom, sign panel & upper façade components.



# Painting

*Painting dramatically changed the appearance and character of this downtown Columbia, SC building.*



**M**any commercial buildings in Perry County were constructed of brick and were unpainted. Whenever possible, keep the wall material of the building its natural, unpainted finish. If it is necessary to paint the building, the preferred approach would be to paint it the color of the underlying natural material. Finally, if the building is to be painted and there is a strong preference to not paint the building the color of the underlying natural material, then a color should be selected that coordinates with the color of the buildings to the subject property's right and left.

Done properly, painting can be one of the simplest and most dramatic improvements one can make to a façade. It gives the façade a well-maintained appearance and is essential to the long life of many traditional materials.

Perry County has pre-approved two historic paint color palettes as noted below. Any colors selected from these palettes will likely be approved.

*Examples of successfully executed painted color schemes on downtown commercial buildings.*



## GUIDELINES

- » Keep historically unpainted buildings unpainted.
- » Utilize historic and compatible paint colors when painting a historic building.
- » Address maintenance issues to the wall materials prior to painting.

## PRE-APPROVED COLOR PALETTES

- » Benjamin Moore: Historical Color Collection
- » Sherwin Williams: Exterior Preservation Palette



# Painting (continued)



*Good examples of rich paint colors that enhance storefronts and create a welcoming pedestrian environment*



## Painting (continued)

*Good examples of how painting can highlight architectural details and provide visual interest on even plain buildings (top right).*



# Repair & Cleaning

**T**raditional building elements should be maintained in order to preserve their integrity as character-defining features. These elements could include, but are not limited to, window sills, ornamental entry doors, cast iron storefront surrounds, masonry wall materials, window hoods and cornices. Surface cleaning should be undertaken with the gentlest means possible. Sandblasting and other harsh cleaning methods that may damage historic building materials are strongly discouraged. Waterproofing and graffiti proofing sealers should be used after cleaning and repair.

## GUIDELINES

- » Abrasive methods such as sandblasting are inappropriate, as they permanently erode building materials and finishes and accelerate deterioration.
- » If cleaning is to be considered, use a low-pressure water wash. Chemical cleaning also may be considered if a test patch is first reviewed and negative effects are not found.
- » Repair deteriorated primary building materials by patching, piecing-in, consolidating or otherwise reinforcing the material.



*Terra cotta cornice cleaning via a low-pressure water wash and mild detergent.*

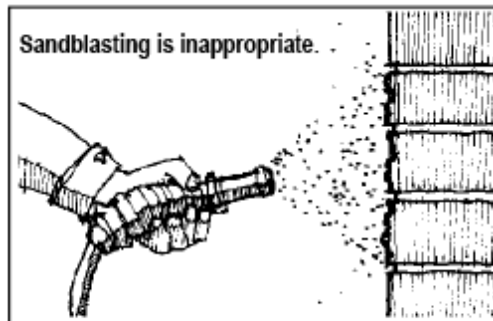

*Use the gentlest possible procedures for cleaning and refinishing historic materials. Abrasive methods such as sandblasting are strongly discouraged, as they permanently erode building materials and finishes and accelerate deterioration.*

## Replacement of Unavailable Components

When traditional construction materials cannot be replaced or matched, care should be taken to match the original pattern, thickness, color, and texture as closely as possible with available replication materials. An abundance of replication components are readily available online. An excellent resource is [www.traditional-building.com](http://www.traditional-building.com).

### GUIDELINES

- » Utilize existing components whenever possible.
- » Utilize compatible components when original components are unavailable.
- » Repair deteriorated primary building materials by patching, piecing-in, consolidating or otherwise reinforcing the material.

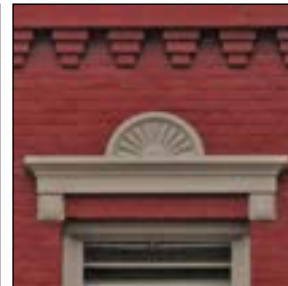

# Additions to Existing Structures

It is normal for buildings to evolve over time as additional space is needed or new uses are accommodated. Additions to existing structures within the overlay district are appropriate as long as they do not destroy traditional features, materials, and spatial relationships that are significant to the original building and site. They also must be distinguishable from, yet compatible with, the overall architectural character of the district.

## GUIDELINES:

- » New additions should be interpretations of the existing buildings whereby the architectural characteristics of the existing structure are incorporated using modern construction materials and methods.
- » New additions should be designed so that if the addition were to be removed in the future, the essential form and integrity of the original structure would be unimpaired.



*Excellent example of a historic church that built a new addition. The new addition did not pretend to be historic, but rather interpreted the historic detailing of the building (e.g., brick patterns, water table, Gothic windows, spire) in contemporary ways and with modern materials.*



*Negative example of a property satisfying the criteria to “be distinct” from the original structure, but failing miserably to “be compatible” with the original structure and it’s district surroundings.*



*These two photos illustrate a good example of an addition to an existing commercial building. The addition does not try to replicate the historic building but complements it through proportions and color.*

---

## Demolitions & Relocations



*Occasionally, demolition is the only course of action that remains for a property. A plan for the site's reuse is a critical component in the evaluation of a request for demolition.*

**D**emolition of existing buildings is strongly discouraged. However, it is recognized that, in some cases, older structures may deteriorate to the point that rehabilitation is technically infeasible. In such cases, it is the responsibility of the property owner to demonstrate that rehabilitation is not appropriate AND demonstrate a clear plan for the re-use of the site and any related new construction after demolition.

### GUIDELINES:

- » If an existing building's condition is deteriorated such that rehabilitation and use of the building is judged to not be feasible, a request for demolition may be considered. It is the responsibility of the property owner to demonstrate that rehabilitation is not feasible.
- » If public safety is threatened, interim steps may be taken to close and stabilize the structure.
- » Any application for a demolition shall include plans for the re-development of the site after demolition.

---

Page left blank intentionally to accommodate double-sided printing.



# New Commercial Buildings

The future is bright in Perry County as public and private investment has created an atmosphere that is conducive to commercial development. The addition of new, infill construction in the downtown area is welcomed and represents a progressive mindset and robust economy. However, there is strong sentiment that new construction in the downtown area respect the architectural traditions that have preceded it. It is not necessary, nor even encouraged, that new construction copy historic styles, but rather interpret those principles and details in a contemporary manner. In so doing, the best of our architectural past is honored, yet a new tradition of architectural style is allowed to flourish.

In the pages that follow, many of the aforementioned traditional architectural principles and details are described so that an accurate understanding and interpretation in new designs can result.



# Building Heights

The majority of buildings in the commercial area of Perry County are 1-2 stories in height. (See photos below) While there are exceptions in the downtown areas, new buildings should strive to be compatible in height to the buildings to their immediate left and right. For example, a new building planned between two-story buildings on each side should strive to be two stories in height as well. However, if a one-story building is proposed in the same location, a higher-than-normal upper façade and parapet should be considered to help it relate to the two-story buildings that surround it. (See example at right of a one-story McDonald's that utilizes this technique to make it appear as a two-story building.) Buildings that are taller than two stories should utilize techniques such as shorter floor-to-floor heights and running trims to relate to the heights of adjacent shorter buildings. Consult local building codes and zoning ordinances for maximum building heights.

## GUIDELINES:

- » Buildings in the downtown district should relate to the characteristic height of their immediate right and left.
- » Except for areas where existing structures are predominantly single-story, the minimum height should typically be two stories, even if the building contains only one functional story. Low profile buildings will not yield the density and character desired for the downtown area, and should, therefore, be discouraged.



BLAIN



DUNCANNON



NEW BLOOMFIELD



NEWPORT

Typical building heights in commercial districts within Perry County.



This franchise architecture (which is typically one-story tall) utilizes a false upper façade to give it the appearance of being two-stories tall in order to relate to its surroundings.



Prototypical block finds several different façades with various treatments yet a consistent building height that unifies the downtown.

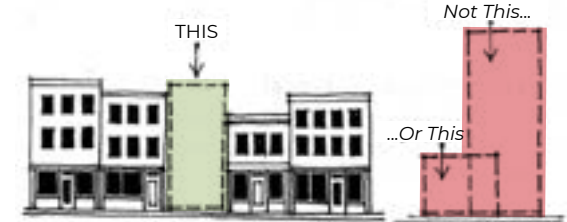

New, infill buildings should be approximately the same height as adjacent buildings.



Good example of a new commercial building that is similar in height – and form – as buildings in Perry County downtowns.

## BREAKING UP A BUILDING FACADE TO ACHIEVE GREATER ARTICULATION

EXISTING

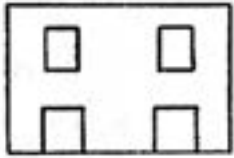

Openings Too Small Relative to Building Mass

1

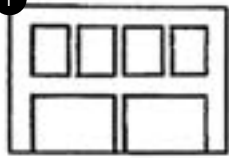

Increase Size of Openings

2



Articulate Openings

3



Break-up Building Mass

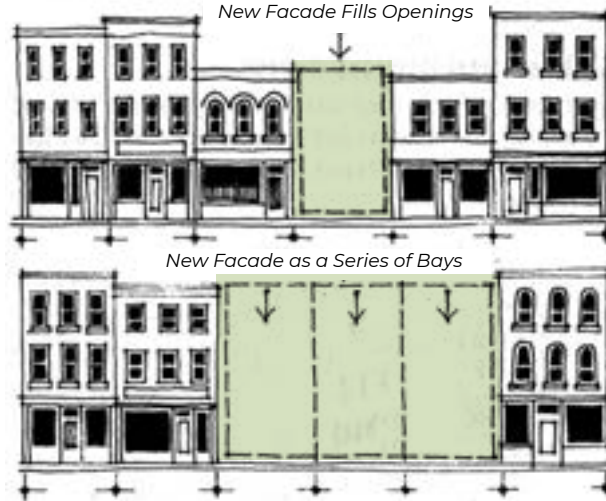

## Façade Proportion & Rhythm

The façade is the exterior of a building that “faces” the street. It is the architectural front of the building and is typically distinguished from other faces by elaboration of architectural or ornamental details.

Building façades, or “frontages,” are critical to the pedestrian quality of the street. The width and pattern of façade elements can help pedestrians negotiate a street by providing a standard measure of progress. This is true regardless of the overall width of the building; for example, a building can extend for the full length of a block and still have a façade design that divides the building into smaller, pedestrian scale bays. The following guidelines deal with establishing a pedestrian-friendly rhythm in new buildings.

### GUIDELINES:

- » The characteristic proportion (relationship of height to width) of existing, adjacent building façade elements should be respected in relation to new infill development.
- » Whenever an infill building is proposed that is much wider than the typical façades on the street, the new building façade should be broken down into a series of appropriately proportioned “bays.”

# Facade Proportion & Rhythm (continued)

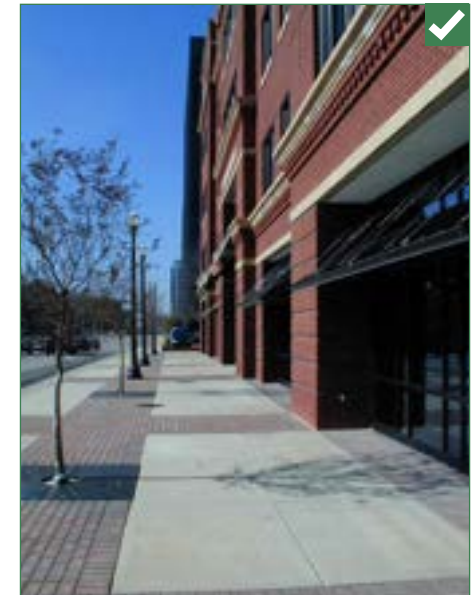

*Blank wall at pedestrian level is unappealing. Scale & proportion of upper floor windows are incompatible with surroundings.*

*Façade articulation (reflected in paver pattern) creates a pleasing pedestrian experience beside this building.*



*Large building sub-divided into bays with clear hierarchy and delineation of entry.*



*Long building sub-divided into bays with clear hierarchy and delineation of entry.*

*Good examples of new commercial buildings that utilize historic façade proportions and rhythm.*

# Alignment of Architectural Elements



EXISTING FAÇADES ARE SIMILAR IN ARRANGEMENT



Dissimilar buildings (in terms of style, color, etc.) are unified by the alignment of architectural elements such as copings, awnings & canopies, storefront heights, etc.



Visual chaos occurs when the alignment of traditional architectural elements are interrupted.

NEW BUILDING FAÇADES

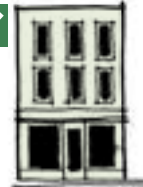

THIS



Not These

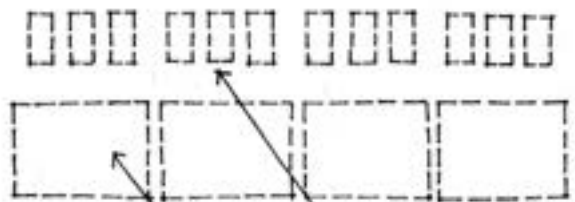

Window Rhythm

Rhythm of Storefronts



Dissimilar buildings (in terms of style, color, etc.) are unified by the alignment of architectural elements such as copings, awnings & canopies, storefront heights, etc.

The alignment of architectural features and elements from one building to the next creates visual continuity and establishes a coherent appearance throughout the downtown. Building façades should be designed to reinforce these patterns and support the area's established visual character. Some façade elements that typically align with adjoining buildings include:

- » Building kick plates or bulkheads
- » Top and bottom heights of first floor display windows
- » Transoms above entrance doors, and clerestory elements in display windows
- » Storefront windows
- » Awnings or canopies
- » Upper story window openings
- » Sign band above the street level
- » Parapet and cornice line
- » Window sills on upper floors
- » Roof lines

When these alignments are not considered, visual chaos can result as illustrated negatively in some of the adjacent photographs.

## GUIDELINES:

- » Whenever an infill building is proposed, the common horizontal elements (e.g., cornice line and window height, width, and spacing) established by neighboring structures should be identified and the infill design should complement what is already in place.

# Roofs and Upper Story Details

The roof is one of the most important details on any building. It has often been said that the two most important places on a building are “where it meets the ground and where it meets the sky.” The upper-story details, such as running trims, windows (with companion sills, lintels, and occasionally hoods), tiles, medallions, recesses, cornice and fascia of a building are important elements to consider as they both create visual interest by their detail and are critical elements for alignment with adjacent buildings.

## GUIDELINES

- » Cornice lines of new buildings (horizontal rhythm element) should complement buildings on adjacent properties to maintain continuity.
- » Radical roof pitches that create overly prominent or out-of-character buildings are discouraged. )
- » In the case of civic structures and churches, however, some roof treatment such as a gable, steeple, dome, or spire is appropriate and adds variety to the downtown skyline.
- » Roof-mounted mechanical or utility equipment should be screened. The method of screening should be architecturally integrated with the structure in terms of materials, color, shape and size.

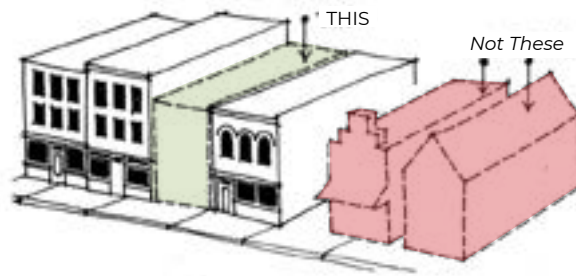

*Occasional variety in the roof line is acceptable, particularly when horizontal alignment with adjacent buildings is maintained. This roof line would have been even more appealing had the original tile roof material been maintained.*



*The triangular treatment at the center of the roof line creates interest and delineates entry. The upper floor details such as precast tiles and recessed panels above the windows creates interest at the second floor.*



*Both variety and uniformity were attained in the treatment of the roof line of these three buildings.*



*The roof form becomes the dominant element of this façade and is incompatible with its surroundings.*



*Good examples of new commercial buildings that utilize pitched roof forms similar to those in Perry County*



*Vertical elements such as towers or church spires create variety on the city skyline.*

# Wall Materials

The use of brick or wood as the primary building material is encouraged, but not mandated, to reflect traditional building patterns in the commercial area of Perry County.

The following materials are generally inappropriate as primary wall materials:

- » Coarsely finished, “rustic” materials, such as wood shakes, shingles, or plywood.
- » Corrugated metal
- » Stucco surfaces, especially synthetic stucco applications
- » Metal slipcovers
- » Residential type sliding glass doors
- » Imitation wood or stone siding
- » Plastic molded imitations of any conventional building material when near the pedestrian level
- » Mirrored or metalized reflective glass

## GUIDELINES

- » Wall materials should be selected to coordinate with neighboring structures and the overall downtown context.

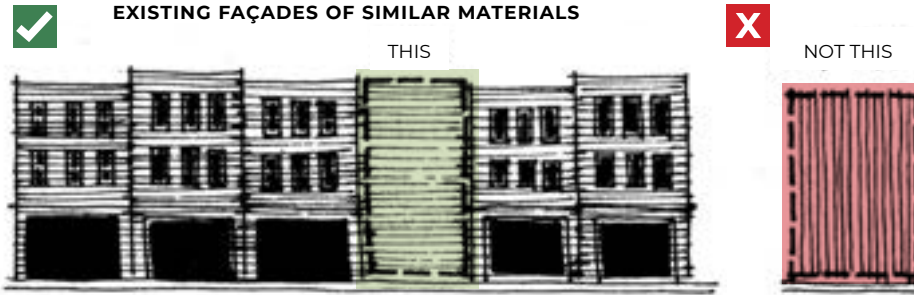

The preservation of the existing brick on this building relates it to the entire downtown area.



The reflective glass of this building would be highly inappropriate in a context such as Perry County where brick is the predominant building material.



As seen in the above four photos, the predominant building material in Perry County's downtown commercial districts are brick or wood siding.



# Piers/Building Frame

*Traditional relationship of storefront & window elements to the building frame or piers.*

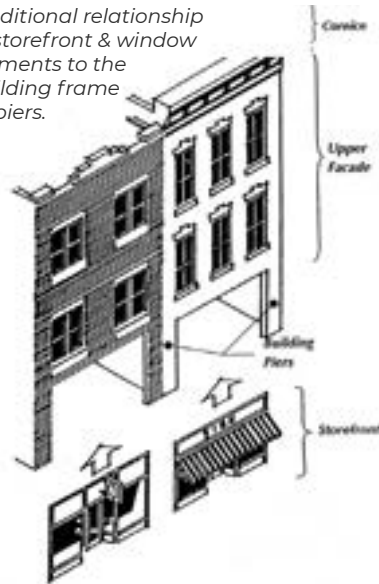

*The piers on this building are expressed clearly by virtue of their material, color, and continuity from the first floor to the upper floor.*

The piers that frame the storefront and visually anchor the upper façade play an essential role in creating the unified architectural framework that organizes the street level's visual diversity. Where these piers have been eliminated or reduced in size, the architectural definition of the façade will appear weak and the upper architecture inadequately balanced. The piers' width and spacing should give both structural and visual support to the façade.

## GUIDELINES

- » To emphasize the piers' integral role in defining the architectural character of the upper façade, they should be treated with the same surface material.
- » Piers which segment the storefront are recommended on wide buildings to improve proportional balance. (See upper left example.)
- » Awnings and storefront elements should be constrained within the piers to further emphasize the vertical and supporting nature of the piers to the upper floor.



*The absence of framing piers and their replacement with visually inappropriately sized columns make the building look as though it will collapse on itself.*

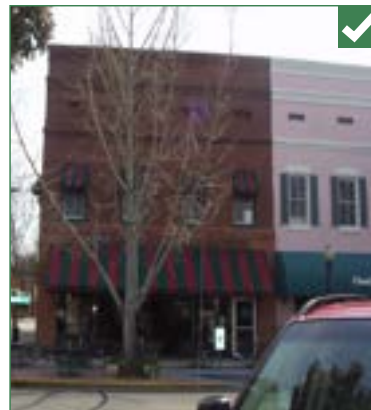

*These two buildings do a good job of expressing the masonry piers that support the upper façade. However, they could have been improved had the awnings been constrained within the piers.*

# Doors & Windows

Front doors and primary entrances are among the most important elements of traditional buildings. Likewise, the placement, size and detailing of windows in the façade are among the most character-defining elements of a building. These two elements in new construction must simultaneously relate harmoniously to the new building while being compatible with adjacent buildings and the overall nature of doors & windows in the district.

## GUIDELINES

- » Doors in new structures should reflect the proportions (height and width) of doors in the existing structure and/or the district.
- » Windows should be compatible in proportion, shape, location, pattern, and size with windows of the characteristic structures in the commercial downtown district.
- » Windows in new structures should reflect the window patterns and proportions of the existing structures in the downtown area and utilize similar materials as found on most doors and windows in the district.



*Full-lite, wood doors, as shown in these two photos were traditionally used in downtown commercial districts. Contemporary materials and interpretations of this tradition are appropriate.*



*Example of new construction that interprets historic patterns of doors and windows while using contemporary materials and detailing.*



*The consideration of horizontal alignment of door (storefront) and window elements in new building to the right unifies these three buildings of dissimilar heights, colors and detailing. Predominantly 2-over-2 window patterns used here.*



*The storefront windows on the first level and regularly spaced punch windows on the upper floors demonstrate how a new commercial building can reflect traditional early Twentieth Century commercial buildings.*



*The window placement on these new mixed-use buildings reflects traditional window placement found in Perry County buildings.*



# Storefront

The first floor of downtown commercial buildings should be primarily transparent, with a pedestrian orientation and “storefront appearance.” It should be noted that the term “storefront” does not necessarily imply that a building has a retail commercial use; storefronts are simply the transparent entry parts of the building that face the street and connect with the sidewalk.

## GUIDELINES

- » The main entrance to a building should be emphasized to delineate a clear point of arrival, or entry.
- » Commercial storefront entries should typically be recessed and/or sheltered by a covered arcade structure, canopy, or awning. This provides more area for display space, a sheltered transition area to the interior of the building and emphasizes the entrance.



Successful “contemporary interpretation” of the traditional storefront separating the “display windows” with brick piers, and maintaining recessed door entry.



Successful “contemporary interpretation” of the traditional storefront, with three-part vertical & horizontal composition. See diagram at right.

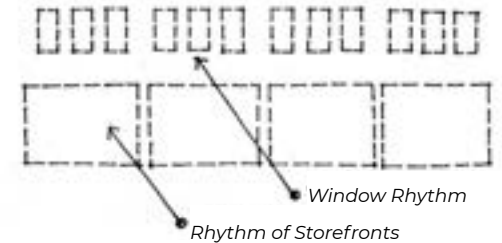
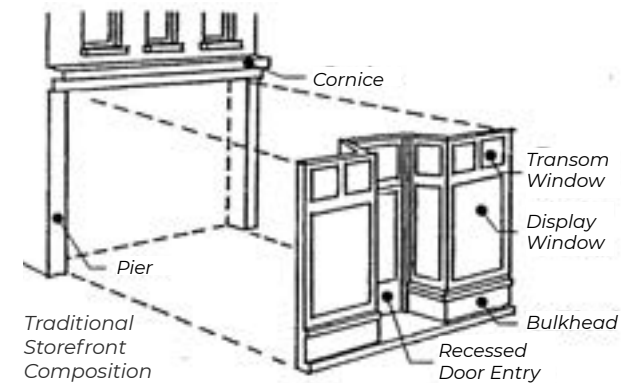

Successful “contemporary interpretation” of the traditional storefront. This building uses a glass canopy to create the covered entry of a historic storefront canvas awning.

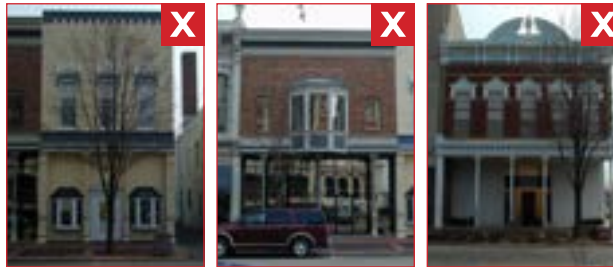

Examples of inappropriate storefront alterations. From left to right: new storefront features a “colonial theme” that is stylistically inappropriate; reflective glass prohibits pedestrian interaction with the storefront; storefront has been removed entirely and covered up with incompatible wall material and columns appear undersized and “weak.”

# Awnings & Canopies



Variety of acceptable awning and canopy types appropriate for new commercial buildings.



Metal and glass canopy interprets the historic role of a canvas awning or metal canopy and clarifies entry on this new building.

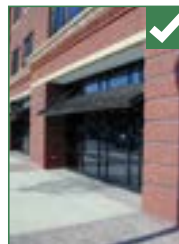

Metal canopy interprets the historical role of the traditional canvas awning.



Steel canopy interprets the historical role of the metal canopy.



Canvas awnings (left) and metal canopies (right) on these two new commercial buildings illustrate appropriate awning treatments that respond to the windows, doors, and associated architectural forms.



The awnings on this new commercial building are well-executed and respond to the window and doorway openings.

Awnings should be designed to fit the storefront opening, and emphasize the building's proportions. Awnings should not obscure or damage important architectural details. Where possible, align awnings with others on the block, particularly the bottom edge. Mount the top edge to align with the top of the transom. While it is generally preferred that no signage be applied to the body (or sloped portion) of the awning the valence may be used for simple signage such as the name or address of the business located in the subject building.

## GUIDELINES

- » Awning color should be coordinated with the color scheme of the building. In general, solid color awnings should be used on buildings with intricate and abundant architectural detailing, while striped awnings might be utilized on simpler buildings to introduce color and vitality.
- » Metal canopies that are similar in form to fabric awnings may be appropriate when designed as an integral part of the building façade and not appearing as tacked-on additions.
- » It is strongly preferred that awnings in the downtown commercial area not utilize vinyl nor be backlit.

# Balconies

**B**alconies are railed or balustraded platforms that project from the building to create a sense (sometimes actual, sometimes implied) of the interior of a building being extended to the outside. When used appropriately in new buildings, balconies can add color, detail and functionality that a building would otherwise lack.

## GUIDELINES

- » Integrate the balcony into the structure either by setting it into the building or by incorporating a well-detailed supporting bracket system.
- » Introduce ornament and detailing in balcony railings to add character and visual interest to the building.
- » Use appropriately scaled and detailed brackets or supports.



*Contemporary interpretation of traditional balcony element creates a sense of extending the inside of the building to the outside.*



*Well executed balcony and support bracket.*



*Appropriate balcony installation in Aiken, SC.*



*Positively, this balcony installation provides a level of detail/ornament. Negatively, it should be questioned why you would have a balcony that is inaccessible/non-functional since the windows behind are fixed in nature.*



*Contemporary interpretation of traditional balcony element on this building introduces color and detail.*



*Example of portico balcony/canopy from Aiken, SC.*

---

Page left blank intentionally to accommodate double-sided printing.

## Existing Residential Buildings

The renovation of existing residential structures provides an excellent means of maintaining and reinforcing the architectural character of Perry County's traditional downtown neighborhoods and should be encouraged. Renovation and expansion not only increases property values in the area but also serves as an inspiration to other property owners and developers to make similar efforts.

When an existing structure is to be renovated or expanded, care should be taken to complete the work in a manner that respects the original design character of the residence as well as the neighborhood in which it resides. The appropriate design guidelines in this chapter are provided as an aid to owners whenever a residential-type structure is to be renovated or expanded.





## Color of Materials



*The use of the green, brown, and off-white paint colors adds interest to this tan brick residence.*



*The colors represented by both the painted buildings and unpainted buildings in this row of buildings provides visual interest.*



*The use of an accent color—in this instance the red of the shutters—can create a dramatic contrast to the white wood siding.*

Colors of materials should be selected to be harmonious with the design and age of the structure and with properties in the immediate vicinity.

The impact of color on the setting must be considered. For most buildings, particularly those in a residential area, colors should complement and blend with those used in the vicinity. Different or contrasting colors should usually be reserved for important public buildings.

For a listing of pre-approved paint color palettes, please see on page 41.



*The pale blue siding is contrasted nicely by the brown trim accent color.*

# Foundations

Rehabilitation projects involving foundation work should preserve the original appearance and materials of the foundation. If an open foundation must be enclosed, the infill should be either a simple wood lattice or a well-ventilated enclosure using material similar to that of the original foundation. If possible, the enclosure should be recessed to preserve the original foundation pier appearance. Additional foundation vents should be compatible in style and material with the structure.

Although some of Perry County's old structures have basements or have floors at grade level, the most common materials used for the supporting base of old buildings in Perry County is brick or stone.

Foundations should not be altered to disguise problems, which must be identified and solved. Typical problems are cracks from differential settlement, failure due to inadequate structure, decay of materials, and damage from renovations.

The following are among the considerations used to decide whether foundation alterations are appropriate.

- » The cause of foundation problems must be addressed and repairs made before any proposed cosmetic alterations to hide damage will be considered.
- » Windows, doors, or other openings should not be enlarged or cut into a foundation unless the size and placement of the new openings are compatible with the design of the building and its structural integrity.
- » Decorative, original foundation vents should be retained.
- » Additions to a foundation, such as new porch piers, should match the appearance of old, intact materials.



*Decorative foundation vents on this building provide ventilation to the sub-floor area.*



*Wood lattice placed between brick foundation piers provides ventilation to the crawl space.*

## Exterior Materials



Wood siding is a common building material in Perry County.



New Bloomfield - Brick is a common building material in Perry County.



Millerstown - Stone is a common building material in Perry County.

Original exterior materials should be maintained to the greatest degree possible. The application of artificial materials is strongly discouraged.

Common exterior wall materials of historic houses in Perry County included brick, stone, and wood clapboard siding. If properly maintained, all of these materials can last for many years. Changing the exterior material, even to one that mimics the original, affects the appearance of the building.

# Exterior Materials: Wood

An advantage to wood over vinyl and aluminum siding is the relative ease of successful minor repairs. Since vinyl can change color and the finish on aluminum can wear, small, inconspicuous repairs to these materials can be difficult or impossible. Removing a large area of old wood siding or shingles is rarely necessary. Depending upon the type of damage, various techniques can be used to repair clapboards, board-and-batten siding, and drop siding. When necessary, even one deteriorated wood shingle can be removed and replaced.



BLAIN



MARYSVILLE



LANDISBURG



MILLERSTOWN

*Perry County has a rich tradition of the utilization of wood siding as a predominant building material.*

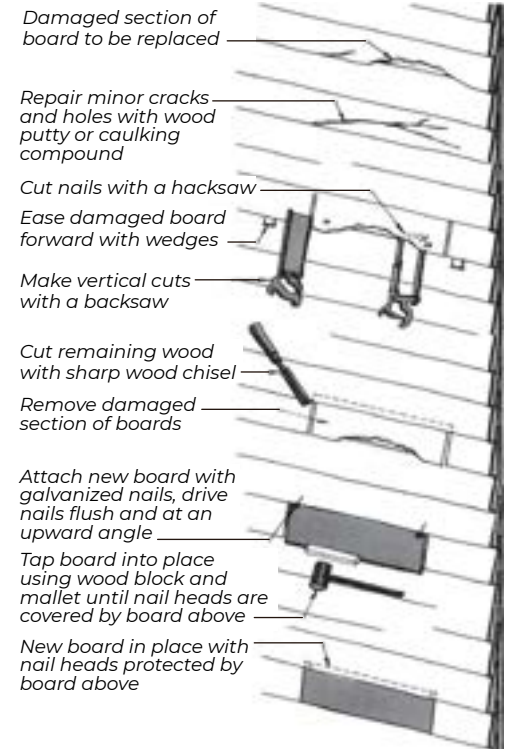

*Damaged wood siding should be repaired as soon as possible to prevent problems. Fillers can be used for minor repairs. A large damaged area can be repaired as illustrated above. Replacement of an entire board usually is not necessary.*

## Exterior Materials: Synthetic & Substitute Siding



*Some disadvantages of vinyl siding placed over wood siding include, but are not limited to: the concealment of any deterioration issues; corner trims and window surrounds that are not sized appropriately; and, an appearance that is "too perfect," and therefore, doesn't look authentic.*

**S**ubstitute and synthetic sidings include vinyl and fiber-cement; aluminum; pressed wood; and asphalt. Masonry and stucco are occasionally used to cover wood siding.

Substitute siding is strongly discouraged and should not be approved if it:

- » would be applied over damaged or rotten materials. All deteriorated materials must first be repaired or replaced with similar materials.
- » does not match the existing or historic materials in size, profile, scale, finish, and articulation.
- » cannot be installed without irreversibly damaging or obscuring the architectural features, trim, or detail of the building.
- » would not be installed in the correct manner with respect to moisture and vapor barriers and design of corner boards.
- » is textured with an exaggerated wood-grain or "sandblasted" finish.
- » would be installed over face brick.
- » would be installed over existing substitute siding.

Substitute or synthetic siding may be appropriate when the siding (without a pronounced texture) would be used for new construction or on rear additions to existing wood frame structures.

A substitute material should not be allowed if it is proposed as a cosmetic treatment or if it could hide, instead of prevent, future damage. A substitute material may be appropriate if:

- » existing materials are poor in quality or are causing damage to more significant old materials;
- » a close match cannot be made between in the original material and new material of adequate quality;
- » building or other code requirements make the use of the original material impossible.

Not only must a substitute material match the appearance of the historic material and meet long-term performance expectations, it must also have similar physical properties or be installed in a way that the differences can be tolerated. The differences in how the substitute material and old materials will weather are important.

---

## Exterior Materials: Masonry

**W**hile brick bonds and patterns were frequently used to embellish old brick structures, other masonry materials are sometimes found as ornamental features. Stone was occasionally employed for foundations or trim, by way of example.

Covering old masonry with another material or other treatments that would mask symptoms instead of solving a problem will not be allowed. Before corrective measures are taken to deal with moisture accumulation, the underlying cause must be correctly identified.



*Perry County has a rich tradition of the utilization of brick as a predominant building material.*

## Exterior Materials: Stone

While not as prevalent for the exterior surfaces of Perry County's old buildings as brick or wood, stone is a common historic material. Moreover, with proper maintenance, stone is a virtually permanent building material. Additionally, with appropriate applications of details and accent colors, buildings that utilize stone appear both stately and interesting.



*Perry County has a rich tradition of the utilization of stone as a predominant building material.*

# Roofs

**R**oof form is an essential design element of all buildings and should be retained. Old roof features that contribute to the style and character of a structure—including steeples, towers, dormers, cupolas, spires, skylights, and vents—should be preserved. New features added to roof surfaces normally should be placed so as not to be visible from public street rights-of-way. Distinctive roofing materials, such as metal, slate, and tile, should be retained and repaired, if possible; when replacement is necessary, the same material should be used.

Gable and hip roofs are the two most common roof forms in Perry County, and they are found on houses of a variety of architectural styles. Radically altering the roof form and pitch where visible from a public street is discouraged because it changes the appearance and style of a structure and also affects the surrounding streetscape.

Preservation of an old roof feature is encouraged because the feature may serve an important purpose and also add to visual interest. Adding conspicuous features, including new skylights, cupolas, or dormers, is discouraged if they would adversely impact the character of an old roof or the design of the affected structure. New roof features must be compatible in size, scale, color, and materials to the historic roof.

Standing-seam metal roofs are also used in Perry County. Metal could be used where the roof shape or a low pitch made other materials inappropriate, and it offered other advantages, including fire and snow resistance, light weight, low maintenance, and low cost.



**LANDISBURG**  
*This residence in Landisburg uses a combination of hip and gabled roofs.*



**BLAIN**  
*The Library in Blain is housed within a former residence that features a gabled roof over the main structure and hipped roof over the wraparound porch.*



## Gutters & Downspouts

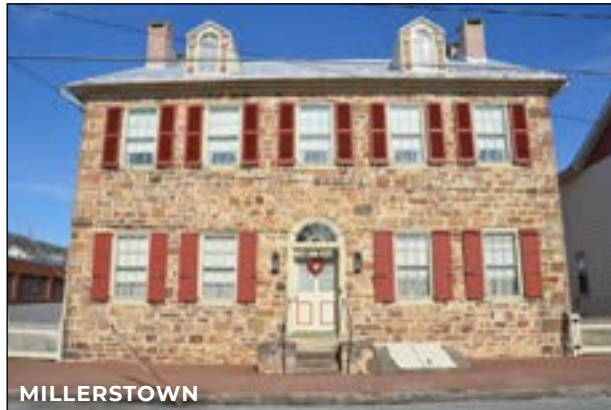

*This residence in Millerstown does a great job of redirecting the gutters from the front facade to downspouts that go down the side facade.*



*The downspouts of these two houses from New Bloomfield are correctly positioned at the corners of the building. By virtue of them being painted the same color as the corner trim, they blend seamlessly into the architecture.*

**G**utters and downspouts should be maintained in their original appearance and location on a building. When the addition of gutters is necessary, it is particularly important that the downspouts be situated at the edges and corners of buildings and along porch supports to minimize the visual impact.

Gutters and downspouts are available in a variety of profiles. When they are replaced or added, usually the style of the old ones should be duplicated. If gutters are needed in a location that is visible from a street, color selection can help camouflage them. Installation of new gutters should not hide any ornamental details.

# Chimneys

Original chimneys are distinctive components of historic structures and should be maintained in their original state rather than covered over with stucco or some other material. Because chimneys have such a significant impact on the appearance of a building, they should not be removed or replaced even if no longer in use.

If a new chimney is added to a building, it usually should be as inconspicuous as possible, and its materials, design, and decorative details should complement existing masonry features.



*The double-flued chimney that anchors the gables of this residence in Landisburg is a distinctive feature that should be preserved.*



**DUNCANNON**

*The number and style of chimneys are important indicators of the age of a building.*

## Porches & Entry Stoops

Porches and entry stoops are usually key design features to retain without alterations. Their repair should not result in the removal of old materials, unless seriously deteriorated. If replacement is necessary and different materials are used, the new materials must be compatible with remaining old materials.

Front porches and entry stoops on primary elevations should not be enclosed. When a porch is enclosed, porch design elements should remain intact and clearly visible. A new porch or entry stoop should not be added to the front of a building unless it restores a missing feature.



*Perry County has a rich tradition of ornate trim associated with the porch structure.*



*Even simple forms and details clearly delineate entry and provide relief from the elements.*



*Asymmetrical placement of the porch is a common design motif in Perry County.*



*This entry stoop features engaged benches.*



*The ornate balusters and fascia of this porch provide handsome architectural detailing to the entrance.*

## Entrances & Doors

Entrances usually should not be altered, enclosed, moved, or added. Old doors and their surrounds should be repaired and retained. If an old door or entrance feature is deteriorated beyond repair, the replacement should match the original as closely as possible. When a significant entrance design element is missing, it should be replaced with one of the same size and of a design appropriate to the type, age, and architectural style of the building. New screen, storm, and security doors should be compatible in design and materials with the entrance and should not detract from the character of the building. Paint should not be removed from a door which was originally painted.

Regardless of the architectural style of a building, the front entrance normally is the focal point of the façade. While a porch may emphasize an entrance, the design of the door and its surround are often detailed in a way to draw attention. Transoms, fanlights, and sidelights were frequently used and not only provide natural light for the interior but also frame a doorway. Pediments and pilasters were often applied in Perry County to accentuate a front doorway.



*Examples of entry designs that should be preserved.*

## Windows & Storm Windows



*The preservation of original window in their original shape and placement, coupled with tastefully applied storm windows on this row of residential form buildings in Duncannon creates a harmonious appearance in their downtown district.*



*Preserving the original windows and trim is a critical determinant in the authenticity of Perry County's residential structures.*



*The new, oversized window on the side of this house would not have been approved by Perry County's Architectural Review Board.*

Every effort should be made to retain the original windows. If they cannot be repaired by a competent carpenter, replacement windows should be of like material and configuration. It is always preferable to keep the original window and use exterior storm windows of the same size and color as the old window frame than to replace the entire window with a new window. In fact, the air space between the old window and a properly installed storm window greatly increases the thermal efficiency of the window unit, and exterior storm windows protect the paint and glazing of the original window and lower maintenance costs.

Shutters which frame the old window are also important to repair and retain. Be sure they are attached with brackets or hinges on the window frame where they belong, and do not simply tack them on to the house.

The type, size, shape, and pane configuration of windows are important, but details, such as the irregularities in old glass and the profile of muntins, can distinguish antique windows. Although new windows offer technological advances and the hope of less maintenance, authenticity is lost with replacements. Replacements touted as being maintenance-free may not be so after the warranty expires and the finishes age. With proper care, old wooden windows can last indefinitely, and often the wood used in windows assembled before World War II is more durable than what is currently available. Retrofitting old windows with weather seals, storm windows, and interior draperies and shutters, can improve energy conservation and noise buffering.

# Windows (continued)

## WINDOWS

The key to successful planning for the treatment of existing windows is a careful, unbiased evaluation of the existing physical condition and needed repairs for each window unit. Often windows look in worse condition than they really are. When a window is loose and air infiltration is a problem, adjustments to stops, new caulking, and weather-stripping may be needed. Damage caused by moisture penetration should be prevented and usually can be repaired, sometimes with consolidants or partial replacement. Wood beneath unsightly paint frequently is sound, but paint failure usually indicates a moisture problem that needs to be addressed. Likely solutions to old window problems are shown on the following pages, and publications providing how-to information are listed in the Sources section at the conclusion of this document.

The decision-making process for selecting a replacement window should not begin with a survey of available contemporary window products; it should start with a look at the window requiring replacement. Attempt to understand the contribution of the window to the appearance of the façade including:

- » the pattern of the openings and their size;
- » proportions of the frame and sash;
- » configuration of window panes;
- » muntin profiles;
- » type of wood;
- » color;
- » characteristics of the glass; and
- » associated details such as arched tops, hoods, or other decorative elements.



The name “window” is derived from a word that literally means “wind’s eye”—indicating the fact that windows at one time were only shuttered openings. Casement windows are a type that predates sash windows.

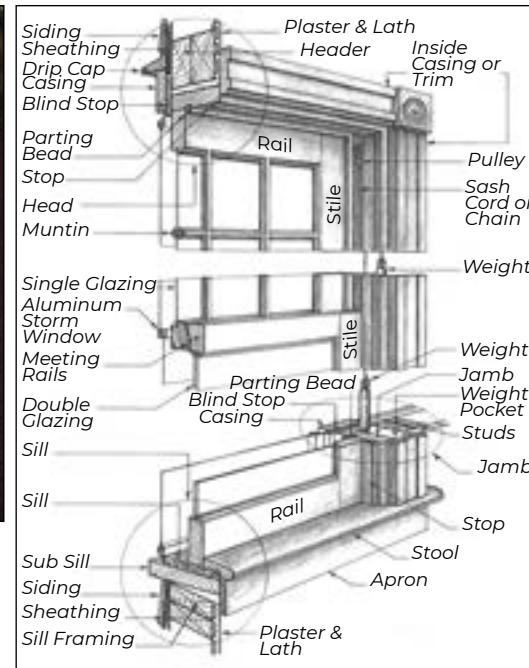

Anatomy of a Double-Hung Window, adapted from Jonathan Poore

Typical parts of an old double-hung sash window. Sash windows, a Dutch invention, arrived in America around 1700. New double-hung windows do not have the sash counterweights shown in the drawing. Access to the counterweights is usually through a panel in the jamb, and broken sash cords can be replaced.

## TYPICAL WINDOW PROBLEMS & SOLUTIONS

(Adapted from: *The Old-House Journal Guide to Restoration*, which contains additional information for diagnosing and correcting window problems.)

PROBLEM	SOLUTION
Sticking sash	Remove paint buildup. Lubricate with paraffin or soap. Check sash cords, counterweights, and pulleys. Plane wood only as a last resort.
Broken sash cord	Replace cord or chain.
Draftiness	Weather-strip & caulk. Check sash locks.
Missing or loose putty	Remove loose putty, re-putty, then paint.
Missing or broken muntin	If possible, repair with epoxy. If necessary, buy or make a new muntin to match the original.
Broken glass	Re-glaze.
Peeling paint	First, eliminate sources of moisture. Then, strip or scrape loose paint, caulk, prime, & repaint.
Rotten or loose bottom rail in lower sash	Brace rail connection with flat angle, or splice in a new bottom rail.
Rotted sash or sill	Repair rotted areas with consolidants, or replace.

## Windows (continued)



*Examples of windows found throughout Perry County.*



Develop an understanding of how the window reflects the period, style, or regional characteristics of the building and/or represents technological development. A replacement window should retain as much of the character of the historic window as possible.

Generally, replacing a window that is too damaged to be repaired with an entire new window of the same material, size, design, details, color, etc. is recommended. Coatings, applied films, and changes in glazing that noticeably alter the color, shade, or reflective qualities of windows will not normally be approved.

The primary concern of the Architectural Review Board or Historic Preservation Commission will be the impact of the project on the design of the structure and on the surrounding area. Non-traditional materials and designs will be allowed as long as there is no adverse visual impact on the neighborhood.

# Windows (continued)

## STORM WINDOWS

Many styles of storm windows are available to improve the thermal performance of existing windows. The use of storm windows should be investigated whenever feasible because they are thermally efficient, cost-effective, reversible, and allow the retention of old windows.

Exterior storm window frames may be made of wood, aluminum, vinyl, or plastic. However, the use of unfinished aluminum storm windows is not allowed, and the storm windows must be sized to fit the windows they cover. The visual impact of storm windows may be minimized by selecting colors which match existing trim color. Arched-top storms are available for windows with special shapes. Interior storm windows do not require Architectural Review Board approval; if they are used, condensation should be prevented by creating a seal on the interior storm sash while allowing some ventilation around the prime window.

If an exterior storm sash is used over a window with leaded glass, it is important to vent the exterior glazing at the top and bottom to prevent buckling of the window the storm sash is intended to protect.



*The careful design and placement of the storm windows in New Bloomfield maintains the character of the historic windows beneath.*

### COMPARISON OF WINDOW FRAME MATERIALS

(Adapted from: Ideas for Great Windows & Doors. Sunset Publishing Corporation, 1993. "Comparing Window Frames," p. 69)

#### WOOD

**Pros.** Durable and insulating, wood window are available prefinished, primed, or bare. If properly maintained, they can last for hundreds of years.

**Cons.** Regular refinishing is essential because wood windows can rot if not properly maintained. Moisture can cause wood frames to stick, and paint buildup can make them both difficult to operate and prone to air infiltration.

**Cost.** Quality and finish dictate the initial cost. Upkeep is an additional, ongoing expense.

#### CLAD WOOD

**Pros.** Wood frames manufactured with a thin layer of aluminum or vinyl have the insulating advantages of wood and do not require exterior maintenance for the life of the cladding material.

**Cons.** Paintable cladding is required if a color other than the limited number of standard share is desired. Rot can occur under cladding.

**Cost.** The cost is about the same as prefinished wood and about 20 percent more than bare wood.

#### VINYL

**Pros.** Insulated vinyl can be more energy efficient than wood, and vinyl without steel reinforcing is as efficient as wood.

**Cons.** Because dark colors absorb too much heat, vinyl frames are normally available in only white or beige.

**Cost.** Not as inexpensive as low-end aluminum windows, vinyl windows can cost as much as premium wood windows.

#### ALUMINUM

**Pros.** A light, strong material, aluminum retains its shape better than wood or vinyl. Color-bonded or anodized aluminum is practically maintenance-free.

**Cons.** Aluminum is prone to scratches and nicks. Even if designed with a layer of nonconducting material to act as a thermal break, aluminum frames are not as energy-efficient as other types of window frames.

**Cost.** The price of aluminum windows varies from equal to about half of the cost of premium wood windows.

#### FIBERGLASS

**Pros.** Strong and durable, fiberglass is more insulating than wood. Window frames are available with a brown or white polyurethane coating that can be painted.

**Cons.** The long-term performance of fiberglass windows, which were debuted in the Northeast in 1990, is unknown.

**Cost.** The cost is close to that of premium wood windows.

#### STEEL

**Pros.** Steel windows, which have factory finishes, are very durable.

**Cons.** Steel window are expensive and are not available in double-hung and slider styles. Although better than aluminum, they are less energy efficient than other window frame materials.

**Cost.** Although competitive for some applications, such as curved or very large windows, steel is the most expensive window frame material.



## Details

*As illustrated by these photographs, residential buildings can contain a wealth of interesting ornamentation and details.*

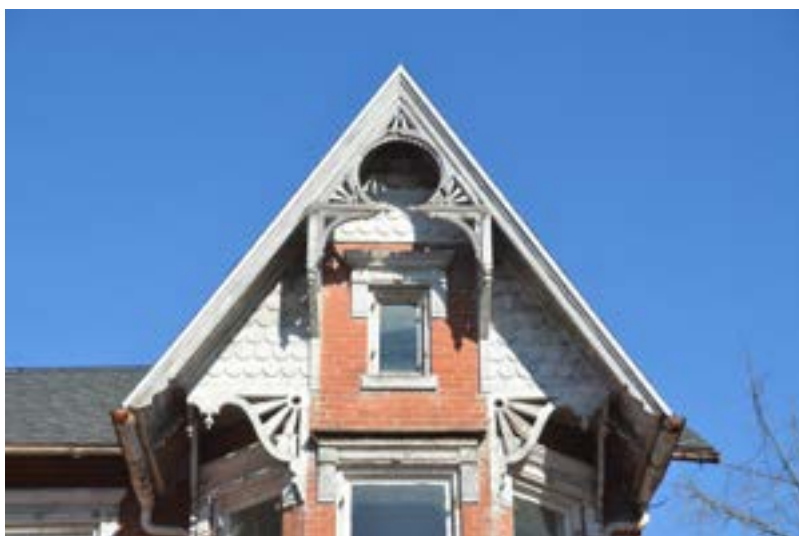

Decorative, craft, and functional details that are important to the historic or visual character of a structure should be retained and protected. Replacement of missing details should be based on documentary, physical, and/or pictorial evidence and be compatible with surviving character-defining features. Application of ornamentation inappropriate to the style, type, and age of a structure will not be permitted.

Important details and ornamentation can often be found on old structures from the foundation level to the chimneys—from decorative grillwork that allows ventilation under the structure to the brick details of a chimney top. They can provide evidence of the age and function of the structure, and they usually are representative of the period or architectural style. Significant details should be identified, maintained, and repaired since they are essential to the character of a structure and reflect the technology, materials, and craftsmanship available when they were created.

Restoration of damaged details should preserve as much original material as possible. If a distinctive detail is missing or severely deteriorated, the replacement should match the old in design, texture, color, and other visual characteristics, and, where possible, materials. Historical photographs, drawings, and descriptions along with physical evidence should be used when planning the reapplication of a lost feature. When adequate documentation to precisely replicate the original detail is unavailable, a new design compatible with the design and other ornamentation of the building and with structures in the vicinity may be appropriate.

Never try to make a building look older, grander, or more rustic than it was originally by using details belonging to another period, style, or type of building. The results of changing significant details are either unconvincing or misleading.

# Code Compliance

Compliance with health and safety codes and handicap access requirements should be carried out with a minimum of impact to the historic character of old buildings.

Health and safety codes and legislation requiring accessibility for the disabled can necessitate alterations to old buildings that are not used as private residences. When compliance is required, owners should work with the City's building inspectors to meet standards and should strive to avoid loss of significant features and spaces. Any changes should be compatible in scale and design with the old structure, and they should, if possible, be reversible.



*This handicapped ramp is inappropriate because it dominates the small building. The enclosure of the front porch also would not meet the Architectural Review Board guidelines.*



*The wheelchair lift provides access near the front entrance and eliminated the need or a ramp. Such lifts are effective for three-to-ten foot changes in elevation.*



*The placement of fire escapes at the rear of buildings usually is appropriate.*



*This appropriate handicapped ramp is easy to locate from the off-street parking area and is inconspicuous from the street.*

# Additions



*The small, one-story additions on the left do not detract from the original design of the house.*

**A**dditions shall respect the character and integrity of original buildings and must not be designed to appear as original components. Typically it is best to position additions at the rear or on view-obstructed sides of buildings. New additions can dramatically change the appearance of structures, and they can hide, destroy, or damage significant old features and materials.

The Review Board's primary concern will be the impact of the design change on the existing residence; such additions should not dominate or clash with old buildings nearby. The Review Board will not normally approve plans for an addition unless all of the following three criteria are met.

## **1. Features and materials important to the character of the structure and its setting would be preserved.**

An addition should be planned to minimize noticeable changes to the design of an old structure and its surroundings and to limit permanent loss of old materials and important spaces. Ideally, the addition should be inconspicuous to passersby. In the future, it should be possible to remove the addition, expose the original craftsmanship and form, and then return the structure and site to the original design.

Regardless of its size, an addition requires the loss of old materials and/or changes to the immediate setting. Placement and design of the addition should take advantage of the fact that all parts of an old building and its site are rarely of equal significance.

Concealment or harm to decorative features should be avoided as should changes to façades and spaces designed to be seen by the public and guests. Consequently, changes to the back or sides of a building usually have the least impact.

## **2. The design of the addition would be compatible with the existing structure and its context.**

The character of each old property is different and is determined by design, materials, and setting. Some design principles that affect character include placement, scale, proportion, shape, massing, rhythm, and directional emphasis; these are explained in the Appendix section of this publication.

A new addition should strongly relate to the existing building, which should retain its prominence. Considerations for making additions compatible include the following.

**Placement.** An addition should be located to minimize changes to the proportions and profile of the old building. Because Perry County's buildings are not tall, rooftop additions or a new story would usually be too conspicuous to be acceptable. Front additions, including decks, are also rarely appropriate. Side and rear additions normally should be set back from the adjacent building wall and roof. The addition of dormers, which can convey a false impression about the original design of a structure, may be allowed on a building if there is no reasonable alternative and the placement can be inconspicuous. Visible garage additions should be avoided; on historic properties, garages were usually separate structures located in the back yard.

**Size, scale, and proportion.** The scale and proportions of an addition should be carefully planned so that the form of the old building is visible and not overpowered. Usually, the height and width of an addition should not be greater than that of the old building, and the floor-to-floor heights should generally appear consistent.

---

# Addition (continued)

**Shape and massing.** The massing and shape of the old building, including its roof type and pitch, should be respected by an addition.

**Rhythm and directional emphasis.** The placement, shape, and proportions of features, such as windows and doors, should relate to the treatment of openings in the old building.

**Materials and details.** Materials and design details should complement the old in their size, texture, color, and other particulars; they do not necessarily have to match the old. Large areas of glass, such as a greenhouse addition, usually should be confined to an inconspicuous location.

### 3. The new addition would be distinguishable from the old and would not create a false impression about the original or historic appearance of the structure.

While compatibility is important, slavish copying of the old building should be avoided. Some difference in detailing, material, or color is needed to clearly indicate that the addition is not a portion of the original structure. Said simply, there is a preference to interpret historic details rather than imitate them. After an addition is constructed, it should still be possible to recognize the original form of the building.



*Built in the early 1900s, this residence was enlarged considerably for use as a hotel. Both rear and side additions were made for the new use. While the brick and roofing of the additions match that of the old structure, the detailing is less elaborate. The form of the original house, which is still dominant, is evident.*

# New Residential Buildings

Construction plans are reviewed to ensure that new residential buildings will be in harmony with the style, form, proportion, texture, and arrangement of old residential structures and that valuable features and open spaces will be protected. An appropriate new building is one that takes design cues from neighboring old structures, that responds to its site, and that utilizes materials which will last indefinitely if maintained.

In planning for the construction of a new residential-type building, the starting point should not be examination of floor plans and favorite architectural styles in pattern books. Instead of being thought of as a sculpture isolated from its setting, a new structure needs to be viewed as a feature of a large composition. The guidelines in this section for new residential-type construction outline some considerations important for a successful design.



# New Buildings

The emphasis on the front of a principal building, which normally should have a strong orientation to the street and details providing human scale, should be on the entrance for pedestrians, not the one for vehicles.

## GUIDELINES FOR NEW BUILDINGS

Not only is it important to be sensitive to the overall character of the neighborhood when planning a new building, it is also crucial to examine the immediate context. Look closely at any old buildings, open spaces, and landscape features that relate visually to the site; these include structures and spaces on the subject property, those visible from the site, and ones that are in the immediate vicinity. The size of the area that should be considered as part of the context and strongly influence the design varies and can be unique for each site.

The neighboring buildings and landscape elements within the context should be examined to determine whether any significant features and spaces or consistent patterns of relationships between structures are present. Also, if the existing structures in the area have a common style or were built during a similar period, that common style should influence, but not necessarily dictate, the design of new buildings. New buildings do not necessarily have to replicate the design or features of neighboring buildings in order to be harmonious.

### SETBACK & PLACEMENT

**New buildings should conform to the setback, placement, and spacing patterns of structures within the context.**

The public spaces within Perry County's traditional neighborhoods are often defined by the front edge of individual structures. This building setback line should ordinarily be maintained with new construction.

Placement of main buildings and accessory structures in relation to side and rear property lines, the curb line, significant open spaces, or each other can also be important to defining public, semi-public, and private spaces. If there is a consistent pattern, the established rhythm normally should be maintained with new construction. Patterns of spacing between buildings and the amount of open space around buildings should also be respected.

New construction within a property should usually retain an established hierarchy or organization of buildings and spaces. The main building can be easily identified, often by a prominent location and the allowance of space around it; the outbuildings are usually smaller, clustered, and frequently oriented to the main building or the other outbuildings. The placement and other design elements of a new building should not make it equal in importance or more prominent than the historic main building.

Always verify legal setbacks required by the City's Zoning Ordinance. Conflicts may be resolved by application to the Board of Zoning Appeals.



*Either of the examples above from Frederick, Maryland would fit harmoniously in most of the residential areas of Perry County.*

# Context & Basic Character

## SIZE, SCALE & PROPORTION

**The size, scale, and proportions of new buildings should conform to that of existing structures if there is a dominant pattern within the context.**

Although the sizes of existing principal structures varies within Perry County's neighborhoods, the scale of buildings within rows of buildings or along one side of a block is generally consistent and is most easily identified by the size of the footprint and number of stories.

New construction should have a comparable number of floor levels to neighboring buildings, whether one-, two-, or three-story levels. A new building should be no higher than the tallest building in the immediate vicinity unless it is to be a significant public building. It should not be shorter than the old main buildings nearby unless it will serve as an outbuilding.

Not only does the number of stories determine a building's scale, but the height of each story, or floor-to-floor height, can also affect the scale of individual buildings. Older buildings typically contained much higher ceilings than those constructed more recently. This is most noticeable in the case of one-story structures where differences in ceiling height dramatically affect the exterior proportions of the building façade. Floor-to-floor heights should be matched as closely as possible to those of surrounding buildings so as to maintain comparable ground-to-eave heights.

Proportions—the relationships between horizontal and vertical dimensions—of new principal buildings should be consistent with old ones within the context, and those of outbuildings should be harmonious with the main buildings to which they relate.

## MASSING & ROOF FORM

**Massing and roof form should be treated in a way that makes the volume, shape, and composition of the new building compatible with existing structures and public spaces within the context.**

The massing of a building—the volume and arrangement of its geometric forms—is key to its visual interest and compatibility with surrounding structures. Massing usually should be similar in complexity to buildings of similar size and type in the vicinity. Large buildings normally require more complex massing than small structures to be in scale with the neighborhood.

Roof form is primarily determined by the shape of a building's floor plan, particularly the exterior walls. The orientation of the floor plan, whether it stretches across its lot or runs from front to back, will determine the look of the roof from the street. The type of roof—gabled, hipped, gambrel, or some variation of these—will project a certain character to the entire structure.

Gable and hip roofs with a moderate pitch are usually appropriate on Perry County's residences. Flat roofs, while acceptable on some nonresidential structures, are usually not allowed within the predominately residential neighborhoods. Unusual roof forms should be used only to accentuate the importance of a significant public building.

## ORIENTATION

**The directional emphasis of the roof form, the massing, and the location of the main entrance for a new building should be similar to that of existing buildings.**

A new structure should be designed to respect the existing pattern of orientation existing within its context.

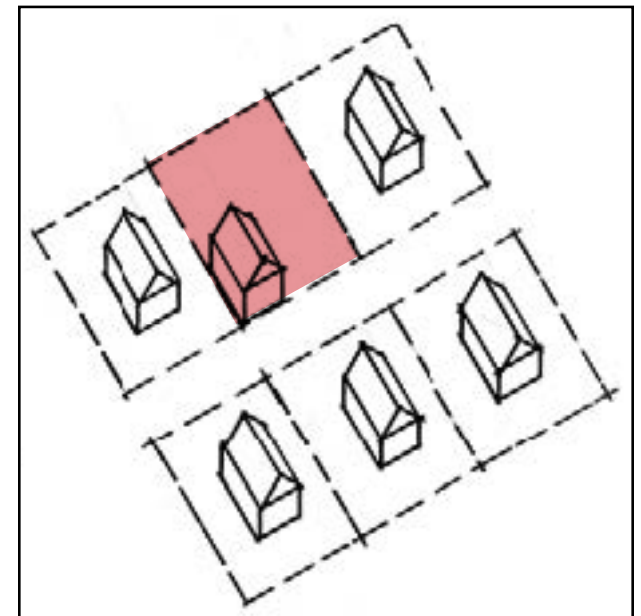

*The placement and setbacks of the building drawn in the top center lot are inconsistent with the pattern set by nearby structures. For new buildings, such inconsistency is discouraged.*

# Site Design

The character of the landscape surrounding a building is an important design consideration. Topography, existing vegetation, sun orientation, access, and site features should be taken into account when planning a new structure.

## SITE FEATURES & OPEN SPACES

**The siting and construction of new buildings should respect significant natural and man-made site features, historic open spaces, and structures.**

Important site features and open spaces, such as old brick walls, garden structures, and significant recreation facilities, should be retained.

## TOPOGRAPHY

**New buildings should be sited and planned to fit the topography of the site.**

The land should not only slope away from a building to prevent moisture damage, it should also meet the foundation in a way that is appropriate. It should not appear that a stock plan was selected for a site the plan does not fit.

## VEGETATION

**Significant existing vegetation, especially plantings from old gardens and trees, should be retained.**

Existing trees and vegetation that provide character to neighborhoods should be protected. New structures should be located to preserve trees. Grading changes and soil compaction within or close to the drip line must be avoided if a tree is to be retained.

## SUN ORIENTATION

**Orientation in relation to the sun should be considered in the design of building exteriors and landscape features and spaces.**

Sun and shade affect the use of interior and exterior spaces, especially porches. For climate control, old houses often employed overhangs, porches, awnings, and other devices to provide shade and help keep interior spaces cool. Similar features are appropriate for new buildings.

Light and shadow can give emphasis to the appearance of design details. The same details on the shaded north side of a structure will look different where illuminated by sunlight.

## ACCESS & PARKING

**New buildings and their sites should be planned to be attractive to pedestrians. Garages and parking lots should not dominate the design of buildings and their sites.**

Old main buildings in Perry County usually have a prominent front entrance for visitors and a comfortable path to that doorway. The same should be true for new structures. Parking for visitors should be convenient to that entrance and should not, by its location, direct guests to private or service entrances. Visitor parking, however, should not cause a building to be set back further from the street than its neighbors or to necessitate paving a large portion of the front yard area.

Where necessary, parking lots should be small and screened. Alternatives to asphalt paving should be considered. Placement of garages and owner parking should usually be inconspicuous and away from the front of the house.



*To protect a distinctive tree, soil compaction, grade changes, trenches, and pavement near and within the drip line should be avoided. Parking under the tree is strongly discouraged.*



*Most old homes were designed to have guests enter through the front door.*





# Miscellaneous Guidelines

PERRY COUNTY DESIGN GUIDELINES

# Artwork

Artwork includes paintings, sculptures, murals and other objects whether attached to a building or freestanding as part of the site design. Perry County has a rich tradition of creative artistic installations of many and varied forms.

## GUIDELINES

- » Retain and preserve artwork that contributes to the overall historic character of a building, site or district.
- » Artwork, when applied or affixed to a building, should be subordinate to the overall building. However, in some instances it may be appropriate for an entire building to be treated as art, especially buildings located along alleys or buildings that are very utilitarian in nature.
- » Artwork should not obscure or damage building elements or details. For instance, a mural should not cover windows. However, a mural may creatively incorporate a window into its composition as long as its function is not compromised.
- » When applied to or affixed to a locally designated historic structure, artwork should not detract from the historic character of the building, site or district, nor should it confuse the public regarding the period of significance of the building or district through false images or details.
- » Consider how art may interpret the history of the community or the building with which it is associated.
- » Consider how art can be incorporated into functional elements such as benches, fences, bike racks, etc.



MILLERSTOWN



NEW BLOOMFIELD

Good examples in Perry County showing application of murals that fit within an overall framework of the architecture. Ideally, the Millerstown mural would have been set below the darker masonry band, however.



Good example of a mural depicting historic interpretation, providing visual interest for the adjacent courtyards space. The panel is framed appropriately within the overall building façade.



Good example of a mural depicting the history of this building. In this case, the building was originally an auto showroom.



Good example of preservation of historic advertising sign.

## Artwork (continued)



Good example of how a colorful mural can encompass a garage or outbuilding like those found along Perry County's alleys. In this instance, there is a community garden adjacent which inspired the theme of the artwork.



Good examples of murals activating blank walls and introducing color and fun. The man on the ladder in the bottom image is actually part of the mural.



Good example of a mural activating a wall of a utilitarian building. The building is home to the local public works department. The mural depicts the focus of that entity. Note how the upper floor windows are incorporated into the mural.



Good example of how a mural can depict community character and take advantage of a service door.

# Artwork (continued)



*Good examples showing how art can be applied to functional elements.*



*Good examples showing how art can be applied to functional elements.*

# Signs



In Perry County's boroughs, as in many American towns, the visual distinction between the traditional downtown business district and outlying general commercial strips in the townships has become blurred. Sign manufacturers and designers have encouraged businesses downtown to install the type of large-scale signs used along commercial highways, where signs need to be larger to attract the attention of motorists passing at high speeds. Pedestrian-oriented commercial areas, such as those found in the boroughs were designed to accommodate shoppers strolling along sidewalks and motorists driving at slower speeds. Signs to attract the attention of these passers-by should accordingly be encouraged. This chapter provides guidance on how to evaluate the quality of signs to ensure that this is done in a manner sympathetic to the architectural character of Perry County.

While size is an important aspect of signs, proper sizing does not ensure an attractive sign. Other considerations such as location, lettering style, color and illumination are also very important in designing an attractive, functional sign. The guidelines that follow address these issues, and others, and are intended to help business owners install quality signs that add to and support the architectural character of Perry County.

## GENERAL GUIDELINES

The following general design guidelines should be considered prior to developing signs for any project.

### COLOR

Color is one of the most important aspects of visual communication. It can be used to catch the eye or to communicate ideas or feelings.

- » Limit the total number of colors used in any one sign. Small accents of several colors may make a sign unique and attractive, but the competition of large areas of many different colors decreases readability.
- » Contrast is an important influence on the legibility of signs. Light letters on a dark background or dark letters on a light background are most legible.
- » Colors or color combinations that interfere with legibility of the sign copy or that interfere with viewer identification of other signs should be avoided. Bright day-glo (fluorescent) colors should be avoided as they are distracting and do not usually blend well with other background colors.
- » Sign colors should complement the colors used on the building and the context (i.e., adjacent buildings and overall block) as a whole.
- » Advertising signs should not be painted directly over entire brick façades, however, smaller wall-painted signs can be appropriate. Antique/historic painted signs (e.g., "Coca-Cola Signs") or advertisements may be preserved and restored when they add to the overall character of the building. These types of signs are not counted as signs per local ordinances if they do not relate to the business occupying the building.

---

# Signs (continued)

## MATERIALS

The following materials are recommended for signs:

- ~ Wood (carved, sandblasted, etched, and properly sealed, primed and painted, or stained).
  - ~ Metal (formed, etched, cast, engraved, and properly primed and painted or factory coated to protect against corrosion).
  - ~ High density pre-formed foam or similar material. New materials may be very appropriate if properly designed in a manner consistent with these guidelines, and painted or otherwise finished to compliment the architecture.
  - ~ Custom neon tubing, in the form of graphics or lettering, may be incorporated into several of the above permitted sign types.
  - ~ Sign materials should be compatible with the design of the face of the façade where they are placed.
- » The selected materials should contribute to the legibility of the sign. For example, glossy finishes are often difficult to read because of glare and reflections.
  - » Individually-mounted internally illuminated channel letters, and internally illuminated plastic-faced cabinet signs are generally discouraged.
  - » Paper and cloth signs are not suitable for exterior use because they deteriorate quickly. Paper and cloth signs are appropriate for interior temporary use only. The use of signs on paper or cloth should be the result of careful thinking about readability and the resultant image of the business.

## SIGN LEGIBILITY

An effective sign should do more than attract attention, it should communicate its message. Usually, this is a question of the readability of words and phrases. The most significant influence on legibility is lettering.

- » Use a brief message whenever possible. The fewer the words, the more effective the sign. A sign with a brief, succinct message is easier to read and looks more attractive. Evaluate each word. If the word does not contribute directly to the basic message of the sign, it detracts from it and probably should be deleted.
- » Avoid spacing letters and words too close together. Crowding of letters, words or lines will make any sign more difficult to read. Conversely, over-spacing these elements causes the viewer to read each item individually, again obscuring the message. As a general rule, letters should not occupy more than 75% of sign panel area.
- » Limit the number of lettering styles in order to increase legibility. A general rule to follow is to limit the number of different letter types to no more than two for small signs and three for larger signs.
- » Avoid hard-to-read, overly intricate typefaces and symbols. Typefaces and symbols that are difficult to read reduce the sign's ability to communicate.
- » Avoid faddish or bizarre typefaces if they are difficult to read. These typefaces may be in vogue and look good today, but soon may go out of style. The image conveyed by the sign may quickly become that of a dated and unfashionable business.
- » Use symbols and logos in the place of words whenever appropriate. Pictographic images will usually register more quickly in the viewer's mind than a written message.

## SIGN ILLUMINATION

The way in which a sign is to be illuminated should be considered carefully. Like color, illumination has considerable value for visual communication.

- » First, consider if the sign needs to be lit. Lights in the window display may be sufficient to identify the business. This is particularly true if good window graphics are used. Often, nearby street lights provide ample illumination of a sign after dark.
- » If the sign can be illuminated by an indirect source of light, this is usually the best arrangement because the sign will appear to be better integrated with the building's architecture. Light fixtures supported in front of the structure cast light on the sign and generally a portion of the face of the structure as well. Indirect lighting emphasizes the continuity of the structure's surface, and signs become an integral part of the façade.
- » Whenever indirect lighting fixtures are used (fluorescent or incandescent), care should be taken to properly shield the light source to prevent glare from spilling over into residential areas and any public right-of-way. Signs should be lighted only to the minimum level required for nighttime readability.
- » Back-lighted solid letters, or channel letters, are a preferred alternative to internally illuminated letter signs. Signs comprised of opaque individually cut letters mounted directly on a structure can often use a distinctive element of the structure's façade as a backdrop, thereby providing a better integration of the sign with the structure.
- » The most appropriate type of sign illumination is indirect lighting. Again, indirect lighting helps the sign to appear as an integral part of the façade, not something that was added later. Indirect lighting is also more appropriate for historic or traditional downtown commercial districts and produces a more intimate ambiance on the street.

## Signs (continued)



### WALL/PANEL SIGNS

Signs should be placed consistent with the proportions and scale of the elements within the structure's façade. A particular sign may fit well on a plain wall area, but might overpower the finer scale and proportion of a lower storefront. A sign which is appropriate near an entry may look tiny and out of place above the ground level.

- » Signs should be located where architectural features or details suggest a location, size, or shape for the sign. The best location for a wall sign is typically a band or blank area between the first and second floors of a building.
- » Signs should be placed on buildings consistent with sign locations on adjacent buildings. This can establish visual continuity among store fronts. See Section "4.3. Alignment of Architectural Elements" on page 105 of Architectural Elements.
- » In pedestrian-oriented areas, such as in the borough centers, signs should relate to the sidewalk instead of motorists. In this case, small projecting signs or signs under awnings are very appropriate. Place signs in close proximity to the store entrance.



### PROJECTING SIGNS

Projecting signs, or those which extend perpendicular from the building, are one of the most historically appropriate sign methods. The number of projecting signs per business should be limited to one. The distance between projecting signs should be at least 30'-40' to avoid too many signs competing for the pedestrian's attention.

- » On a multi-story building, the sign should be suspended between the bottom of the second story window sills and the top of the doors or windows of the first story. On a one-story building, the top of the sign should be suspended in line with the lowest point of the roof.
- » The sign should be hung at a 90 degree angle from the face of the building.
- » The bottom of the sign should maintain at least a 8-10 foot pedestrian clearance from the sidewalk level. Consult the relevant borough zoning ordinance for specific mounting height requirements.
- » Signs which project over a public right-of-way may require a sign or encroachment permit.
- » Decorative iron and wood brackets that support projecting signs are encouraged.
- » The supporting brackets should relate to the shape of the sign. The most important feature of a bracket should be its ability to hold up the sign.
- » To avoid damaging brick and stonework, brackets should be designed so that they can be bolted into masonry joints when possible.

# Signs (continued)



BLAIN



NEWPORT



NEW BLOOMFIELD



NEW CUMBERLAND, PA



NEWPORT

**X** *Bad example showing how a sign is incongruous with the architecture. This business is a great example of maintaining the historic residential character of the building, however, a sign that fits within the arch of the millwork on the porch would be much more effective.*

*One can instead imagine the circular sign (below, left) fitting into this arch nicely, or the simple rectangular sign (below, right) projecting from the building rather than mounted to the millwork.*



MECHANICSBURG, PA

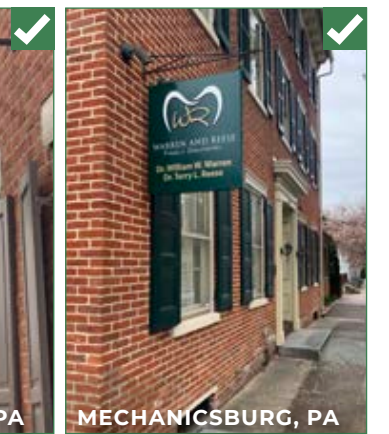

MECHANICSBURG, PA

*Good examples in Perry County projecting signs in a variety of styles and materials. The important thing to note is the simple messaging included on the sign-primarily the name of the business.*

*Good example of a projecting sign that complements the Art Deco elements of a portion of the façade (not visible in this view). The sign would be more effective, however, the messaging was limited to only the name of the business.*



## Signs (continued)



MECHANICSBURG, PA

*This storefront would be much more effective by not obscuring the interior with window signs. The awning sign and lower window graphic band are quite effective, however.*



BALTIMORE, MD



GLEN BURNIE, MD

*Bad examples showing how numerous window signs detract from the appearance of the business and overwhelm customers with too much information (left).*



MECHANICSBURG, PA



HAVRE DE GRACE, MD

*Good examples of window graphics that still allow for views into the interior.*

### WINDOW SIGNS

(Note: Consult borough zoning regulations to determine if temporary signage mounted on the inside of a store window is counted in the overall sign square footage limits.)

- » In general, window signs (permanent or temporary) should not cover more than 50 percent of the area of each window.
- » Window signs should be limited to individual letters and logos placed on the interior surface of the window and intended to be viewed from outside.
- » Window signs should be located so that they do not block views into the business. A visible bakery display case is more effective advertising than a sign.
- » Painted window signs represent one of the most treasured historic sign art forms and should be encouraged when executed by a skilled professional.
- » Glass-mounted graphic logos may be applied by silk screening or pre-spaced vinyl die-cut forms.

# Signs (continued)

## AWNING SIGNS

Placing signage on the body, or sloped portion, of an awning is generally discouraged. However, simple signage such as the address or name of the business placed on the valence is generally appropriate.

- » The text copy should be limited to the address or name of the business only. Letter color should be compatible with the awning and the building color scheme.
- » Backlit awnings and vinyl material are discouraged.

## FIGURATIVE SIGNS

Signs which advertise the occupant business through the use of graphic or crafted symbols, such as shoes, keys, coffee pots, books, etc. are encouraged. Figurative signs may be incorporated into any of the allowable sign types identified above.



BALTIMORE, MD

*Good and bad of awning signs. The awning in the foreground limits message to the business name. The red awning in the background includes too much information and does not fit well within the overall frame of the awning itself.*



WAITSFIELD, VT



LIVERPOOL

*Good examples of freestanding and awning signs. Both limit the messaging primarily to the name of the business and are well designed.*

# Signs (continued)



LARAMIE, WY



---

# Automobile-Oriented Uses

## DRIVE-THROUGH USES

Businesses with drive-through services are more suitable for suburban areas than for downtown districts. The dedication to accommodating the automobile makes it difficult to locate buildings along the street frontage as is the pattern for downtowns and disrupts the pedestrian environment. If these uses are permitted in downtown, then care should be taken to minimize negative impacts.

- » As much as possible, provide ingress to and egress from the drive-through (or at least one of these) from rear alleys or side streets to minimize disruption to the pedestrian environment along the main street.
- » If located along the main street, provide an architectural cover over the drive-through lane to extend the architectural street edge.
- » Continue the sidewalk paving across the drive-through apron to emphasize that the pedestrian has priority.

## AUTOMOTIVE SERVICE USES

Automotive service uses are necessary businesses for the functioning of Perry County communities. While these uses are not desirable in downtown districts, some exist prior to changes in zoning ordinances or some boroughs may still allow for these uses in downtown. If not located downtown, they are certainly located along the approaches to downtown and impact the image of the community. While many of the guidelines outlined in this document are not applicable to these uses because they do not follow traditional patterns of development, it is possible to treat them in a manner that they can contribute positively to the overall community character.

- » Utilize an architectural design that is appropriate to the use rather than treatments that try to make it appear as something it is not.
- » Articulate the façade and roofline to divide long buildings into smaller components.
- » For one-story uses, exaggerate the height of the building with parapets and/or pitched roofs.
- » Utilize architectural forms that interpret service buildings that have traditionally served agricultural communities such as barns and feed stores.
- » Limit the amount of signage and coordinate signs so that they are part of a family of signs.
- » Utilize color and paint to highlight architectural features such as service bays.

## RE-USE OF SERVICE STATIONS

Service stations within or adjacent to a downtown district are often repurposed for another use such as a restaurant, brew pub, or market. When done well, these new uses take advantage of the service bays and doors to engage the outdoors and utilize some of the parking and canopy area for outdoor seating or activities.

- » Respect the original architecture and highlight unique features.
- » If in good condition, utilize the gas pump canopies as a cover for outdoor dining.
- » Maintain the service doors in operable condition to engage indoor and outdoor spaces.
- » Utilize creative lighting to highlight architectural features and illuminate outdoor gathering areas.
- » Utilize fences, walls, and/or landscape to continue the street edge along the sidewalk and define public and semi-private use areas.



# Design Review Checklists

PERRY COUNTY DESIGN GUIDELINES

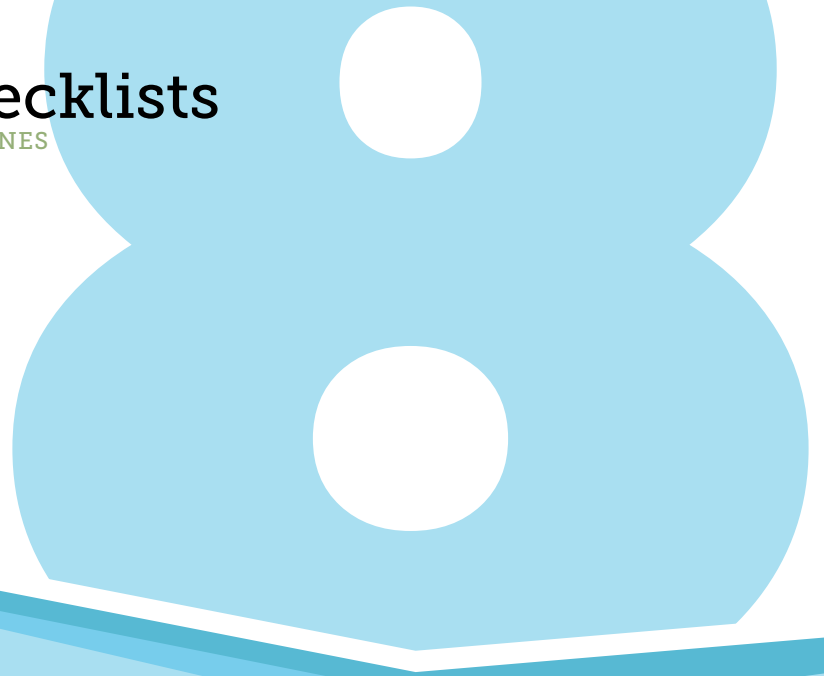

---

# Design Review Checklist

The intent of the checklist is to provide a comprehensive and systematic checklist for the Applicants and the Architectural Review Board (ARB) and to utilize in every case under their review.

An applicant should be able to review the checklist noted herein and determine if their request for design approval satisfies the intent of this document. This checklist will also give the applicant insight into the kinds of questions the Review Board is likely to consider and possibly ask the Applicant. Moreover, it contains questions that elaborate on general concepts presented in the guidelines that might not have been addressed specifically or in great detail, and therefore, lend even greater clarity to the intent of each individual guideline section.

For the ARB, using the checklist will ensure a greater measure of objectivity in the review process, ensuring each Applicant receives the same treatment from the ARB. Additionally, the checklist becomes a basis for motions, referencing appropriate sections of the design guidelines in directive statements. The elaborative questions that follow the checklist outline simply serve to give an understanding in common sense, laymen's terms, of the kinds of information each guideline section is after and which needs to be considered in each review. And finally, the checklist, is provided as a reminder of everything the ARB needs to consider with each application for design approval.

---

## 1. Introduction of Case/Standard Protocol

- » Introduce the Applicant to the process and invite them or their agent to present their design request.
- » Have the Architectural Review Board liaison introduce each case along with any staff recommendations.
- » Invite the public to speak in support or opposition to the case.
- » Call for questions from the Architectural Review Board.
- » Give the applicant an opportunity to respond to each question.
- » After appropriate discussion, call for a motion.
- » Take action on motion as appropriate.

---

## 2. Site Design

### 2.1. Building Setback/Alignment on page 12

Is this building or building porch generally in alignment with adjacent buildings? If a building is missing, what elements have been designed to maintain the "street wall?"

### 2.2. Street Orientation on page 14

Is the entry/storefront of the building oriented toward the dominant pedestrian route? On corner buildings, does the side façade include a partial gesture of entry to address the pedestrian?

### 2.3. Location of Parking/Open Spaces on page 16

If parking is located on the surface, is it placed behind the buildings or on the primary street? Is there a safe and well-lit path leading from the parking area to the main street? Are the 'open edges' of the parking lot screened with appropriate landscaping buffers, low walls, or fences?

If structured parking is utilized, is the structure located behind the buildings along the main street? If located along the main street, is the smallest façade located along that street? Is mixed-use/retail development included on the street level of the garage along the main street? Is the façade of the garage articulated to relate to the scale of the surrounding buildings?

### 2.4. Streetscaping & Landscape on page 19

Are any proposed parking lots buffered with low walls and/or landscaping? Are any trees being removed as a part of this application? If so, are replacement trees being proposed and what is their size, species, and spacing?

---

### 2.5. Alleys/Rears of Buildings on page 23

Is the entrance to the building from the alley or rear treated in an attractive manner? Is the alley/building rear well-lit? How is the screening of mechanical equipment, trash bins, etc. being handled? Are there any potential conflicts between pedestrians and automobiles?

### 2.6. Fences & Railings on page 26

Is a sidewalk encroachment permit required for this use? Is the fencing temporary or permanent? If temporary, is it sturdy and safe and attractive? If permanent, does it utilize materials and detailing appropriate to the building itself and the district as a whole?

---

## 3. Guidelines for Existing Buildings

### 3.1. Preservation of Existing Façade Elements on page 31

Has every effort been made to preserve original and unique features of the original building in subsequent renovation work? Can they be incorporated into the new design?

#### 3.1.1. Removal of Inconsistent Elements

Does the building have a metal slipcover, inappropriate siding or inappropriate signage that could be removed to reveal the historic material of the building? Can a determination be made of the condition of the substrate beneath any inconsistent elements? Do historic photographs exist to aid in this determination?

#### 3.1.2. Storefront Renovation & Replacement

Where transom windows exist, can they be maintained and/or repaired? If the transom is concealed on the interior due to a dropped ceiling, can the ceiling be raised to allow light to penetrate the interior of the building? Are replacement materials compatible with the original? Is the historic storefront composition maintained? Is transparent glass utilized in the storefront display windows?

#### 3.1.3. Window Renovation & Replacement

Are the new windows sympathetic to and compatible with the historical period/style of the building itself and adjacent buildings? If the building has a clear architectural style or construction period, do the windows make logical sense in terms of style (e.g., Victorian buildings rarely, if ever, utilized 6-over-6 or 9-over-9 windows common to Colonial buildings)? Can the original windows (if present) be repaired? Do the replacement windows fit completely within openings of the original windows? Are the replacement windows the same operating type as the original?

#### 3.1.4. Door Renovation & Replacement

Can the existing doors be reasonably repaired? Are the proposed replacement doors representative of most of the doors in the area? Are the doors accentuated with simple details such as brass pulls, kickplates, or a painted sign? Do doors to retail shops contain a high percentage of glass in order to reveal the retail contents and to promote safety? Do the replacement doors comply with the Americans with Disabilities Act (ADA)?

---

#### 3.1.5. Awnings & Canopy Renovation & Replacement

Where several businesses reside in a single building, do the awnings for each simultaneously distinguish, yet relate to and complement, each other? Does the awning fit within the structural bays of the building? Does the shape of the awning relate to the window or door opening? Can the existing frame and/or hardware be used on with the replacement awning or canopy?

#### 3.1.6. Painting

Have all non-paint options been exhausted (i.e., If possible, avoid painting a masonry building; or, if painted seek to remove the paint)? Has the Owner been cautioned about the pitfalls of painting a masonry building in terms of maintenance/upkeep, spalling, etc.? In the case of a painted building, has the Owner been cautioned about not sandblasting as a means of paint removal? If a building must be painted, can it be painted the color of the original substrate? If not, will the new color be compatible with the color of the adjacent buildings? Are the paint colors selected by the applicant drawn from one of the three pre-approved color palettes ?

#### 3.1.7. Repair & Cleaning

Has the Owner been cautioned about the detrimental effect of sandblasting as a means of cleaning or paint removal? Are proposed repair methods the gentlest means possible? Does the Owner understand the fragility of historic building elements and the need to protect them by reasonable means?

#### 3.1.8. Replacement of Unavailable Components

Is the proposed replacement element compatible with the original in terms of detail, size, function, sheen, material, and durability? Will the proposed replacement item be easily detected as a “fake” or will it blend in with the other elements reasonably well?

### 3.2. Additions to Existing Structures on page 46

Is the addition distinguishable, yet sympathetic to the original building? Does the proposed addition follow the general scale, proportion, massing and detailing of the original structure? Is the addition an interpretation -and not a copy- of the original structure utilizing contemporary construction materials and methods? If the addition were removed in the future, would the essential form and integrity of the original structure be impaired? For minor additions (decks, stairs, etc.) are similar materials, colors and design used and are they placed in the least visible locations?

### 3.3. Demolitions & Relocations on page 47

Is there overwhelming evidence that the building cannot be rehabilitated? Has this been demonstrated objectively via structural engineer studies and thorough cost-benefit analysis? Has an independent survey & cost-benefit analysis been conducted by the Borough to determine the authenticity of the Applicant's analysis? Is the only reason the building is being considered for demolition because the Owner allowed the building to be “demolished by neglect?” Are there life-safety concerns to be considered? Can the building be stabilized during a period of time to



---

allow for a thorough study of non-demolition options? Has a definitive plan for the re-use of the site been presented to the Borough or other reviewing entities?

---

#### 4. Guidelines for New Buildings

##### 4.1. Building Heights on page 50

What is the average height of the adjacent buildings? Is the proposed building reasonably compatible with the heights of adjacent buildings? Are any critical details, roof materials, or strong horizontal bands (e.g., cornice treatments, terra cotta roof tiles) of adjacent buildings compromised by the height of this building?

##### 4.2. Façade Proportion & Rhythm on page 51

Has the façade been articulated to relate to the scale of the surrounding buildings (e.g., if an infill building is proposed which is much “wider” than the existing typical façade width, has it been broken down into a series of appropriately proportioned “structural bays” to relate to the traditional building width)? Is there a clear hierarchy to the façade denoting entry? Does the façade inappropriately feature long, blank, unarticulated walls? Have the openings within the façade been articulated to break up the overall façade and to give a “human scale” to the building?

##### 4.3. Alignment of Architectural Elements on page 53

Are the dominant horizontal elements of the building reinforced by the alignment of façade elements such as transoms, bulkheads, cornices, trim bands, awnings, etc. with adjacent buildings? If a building is being designed beside an existing one, are the dominant horizontal elements of the existing maintained on the new (e.g., cornice line; window height; trim bands; etc.)?

##### 4.4. Roofs & Upper Story Details on page 54

Is the proposed roof in character with the surrounding buildings? Does the cornice line have sufficient detail and character to “top off” the building? Is it proportional to the body of the building? Are rooftop mechanical units and equipment screened appropriately? If a pitched roof, does the pitch match that of other buildings in the district?

##### 4.5. Wall Materials on page 56

What is the dominant texture and material of the façade? What is the dominant color of the façade? Are each appropriate to the building, the adjacent buildings, and the buildings within the district? Are there any known deficiencies or performance & maintenance issues associated with the proposed materials (e.g., synthetic stucco)?

##### 4.6. Piers/Building Frame on page 57

Are the piers constructed of the same material as the upper façade? Does the width of the pier have sufficient “visual strength” to appear able to support the weight of the façade above? Are

---

elements such as awnings and canopies constrained within the piers to further strengthen the load-bearing appearance of the piers/frame?

**4.7. Doors & Windows on page 58**

Do the entry doors have a sufficient level of detail & promote views into the building? Do the windows create a sense of scale and visual interest to the façade? Are the window trims compatible with the style of the building and the adjacent buildings? Are the windows proportional to the overall massing of the building?

**4.8. Storefront on page 60**

Does the storefront fit within and reinforce the building piers? Are the materials used appropriate to the building and district? Is the traditional storefront composition addressed or interpreted? Is a transom included or interpreted? Has the bulkhead, or kickplate, been addressed or interpreted?

**4.9. Awnings & Canopies on page 61**

Does the awning/canopy fit within and reinforce the building piers? Does an awning need to be used to address solar heat gain? Would an awning help introduce color and/or detail to add vitality to an otherwise “plain” building? Are the awnings/canopies in alignment with those on adjacent buildings? Are the height of awnings and/or canopies installed at a height in accordance with local building codes?

**4.10. Balconies on page 62**

Is the balcony real or implied (i.e., is it a functional balcony that a person could actually walk or stand on)? Is the level of detailing of the balcony appropriate to the building itself as well as the surrounding district? Are the supporting members of the balcony detailed appropriately?

---

## 5. Guidelines for Existing Residential Buildings

- 5.1. Color of Materials on page 65
- 5.2. Foundations on page 66
- 5.3. Exterior Materials on page 67
- 5.4. Roofs on page 72
- 5.5. Gutters & Downspouts on page 73
- 5.6. Chimneys on page 74
- 5.7. Porches & Entry Stoops on page 75
- 5.8. Entrances & Doors on page 76
- 5.9. Windows & Storm Windows on page 77
- 5.10. Details on page 81
- 5.11. Code Compliance on page 82
- 5.12. Additions on page 83

---

## 6. Guidelines for New Residential Buildings

- 6.1. New Buildings on page 86
- 6.2. Context & Basic Character on page 87
- 6.3. Site Design on page 87

---

## 7. Miscellaneous Guidelines

- 7.1. Artwork on page 90  
If appropriate/applicable, how is the artwork illuminated? If appropriate/applicable, how is the artwork secured in place? Does the artwork contribute to the overall character of a building, site or downtown district? Does the artwork obscure any key elements of a building, site, view or vista?
- 7.2. Signs on page 93
  - 7.2.1. General
  - 7.2.2. Wall/Panel Signs
  - 7.2.3. Projecting Signs
  - 7.2.4. Awning Signs
- 7.3. Automobile-Oriented Uses on page 100
  - 7.3.1. Drive-Through Uses
  - 7.3.2. Automotive Service Uses
  - 7.3.3. Re-Use of Service Stations

---

Page left blank intentionally to accommodate double-sided printing.



# Appendices

PERRY COUNTY DESIGN GUIDELINES

---

# Architectural, Design & Planning Terms

**Alignment** (Architectural) The visual alignment and subsequent placement of architectural elements such as windows, cornice elements, soffits, awnings, etc. from one structure to adjacent structures in order to promote frontages continuity.

**Arch** A curved structure supporting its weight over an open space such as a door or window.

**Articulation** Describes the degree or manner in which a building wall or roof line is made up of distinct parts or elements. A highly articulated wall will appear to be composed of a number of different planes, usually made distinct by their change in direction (projections and recesses) and/or changes in materials, colors or textures.

**Awning** A fixed cover, typically comprised of cloth over a metal frame, that is placed over windows or building openings as protection from the sun and rain.

**Balcony** A railed projecting platform found above ground level on a building.

**Baluster** The upright portion of the row of supports for a porch railing.

**Bay** (Structural) A regularly repeated spatial element in a building defined by beams or ribs and their supports.

**Build-To Line** When placing new buildings in an existing context, it is important to approximately align them with the buildings to its right and left. In these cases, the new building should be “built-to” the line of the existing buildings rather than being considered in terms of setback. See “Setback” herein.

**Bulkhead** The space located between the pavement/sidewalk and the bottom of a traditional storefront window. Sometimes referred to as “kickplate.”

**Canopy** A projection over a niche or doorway; often decorative or decorated.

**Colonnade** A row of columns supporting a roof structure.

**Column** A vertical support, usually cylindrical, consisting of a base, shaft and capital, either monolithic or built-up of drums the full diameter of the shaft.

**Cornice** The horizontal projection at the top of a wall; the top course or molding of a wall when it serves as a crowning member.

**Curb Cuts** The elimination of a street curb to enable vehicles to cross sidewalks and enter driveways or parking lots.

---

# Architectural, Design & Planning Terms

**Eaves** The overhang at the lower edge of the roof which usually projects out over the walls.

**Façade** The exterior face of a building which is the architectural front, sometimes distinguished from other faces by elaboration of architectural or ornamental details.

**Fascia** The outside horizontal board on a cornice.

**Fenestration** The arrangement and design of windows and other openings in a building.

**Frontages** The aggregated façade wall composed of uninterrupted placement of individual urban oriented structures located side-by-side along an entire block as opposed to individual buildings located within the block. The continuity of frontages contributes to what has historically been referred to as the “Main Street Wall of Buildings.”

**Infill** A newly constructed building within an existing development area.

**Kickplate** See “Bulkhead” above.

**Lot** A parcel of land, in single or joint ownership, and occupied or to be occupied by a main building and accessory buildings, or by a dwelling group and its accessory buildings, together with such open spaces and having its principal frontage on a street, road, highway or waterway.

**Masonry Wall** construction of such material as stone and brick.

**Mass** Mass describes three dimensional forms, the simplest of which are cubes, boxes (or “rectangular solids”), cylinders, pyramids and cones. Buildings are rarely one of these simple forms, but generally are composites of varying types. This composition is generally described as the “massing” of forms in a building. During the design process, massing is one of many aspects of form considered by an architect or designer and can be the result of both exterior and interior design concepts. Exterior massing can identify an entry, denote a stairway or simply create a desirable form. Mass and massing are inevitably affected by their opposite, open space. The lack of mass, or creation of perceived open space, can significantly affect the character of a building. Architects often call attention to a lack of mass, by defining the open space with low walls or railings. Landscape architects also use massing in design such as in grouping of plants with different sizes and shapes. Plant masses can be used to fill a space, define the boundary of an open area, or extend the perceived form of an architectural element.

**Monolithic** A single large flat surface (façade) without relief. A massive unyielding structure that has no proportion for people to relate to, nor does it respond to the scale of adjacent buildings.

**Mullions** The divisional pieces in a multi-paned window.

---

# Architectural, Design & Planning Terms

**Ornamentation** Details added to a structure solely for decorative reasons (i.e., to add shape, texture or color to an architectural composition).

**Parapet** A low wall generally running around the outside of a flat roof.

**Pattern** The pattern of material can also add texture and can be used to add character, scale and balance to a building. The lines of the many types of brick bonds are examples of how material can be placed in a pattern to create texture.

**Pier** A stout column or pillar that typically frames the storefront portion of a building.

**Primary Building Façade** The particular façade of a building which faces the street to which the address of the building pertains.

**Proportion** The concept of proportion deals with the ratio of dimension between elements. Proportion can describe height to height ratios, width to width ratios, width to height ratios, as well as ratios of massing. Landscaping can be used to establish a consistent rhythm along a streetscape which will disguise the lack of proportion in building size and placement.

**Recess** A hollow place, as in a wall.

**Rhythm** (Horizontal, Vertical) The regular or harmonious recurrence of lines, shapes, forms, elements or colors, usually within a proportional system.

**Rustication** A method of forming stonework with recessed joints and smooth or roughly textured block faces. A regularly spaced recess in masonry work.

**Scale** (Human) Scale is the measurement of the relationship of one object to another object. The scale of a building can be described in terms of its relationship to a human being. All components of a building also have a relationship to each other and to the building as a whole, which is the “scale” of the components. Generally, the scale of the building components also relate to the scale of the entire building. The relationship of a building, or portions of a building, to a human being is called its relationship to “human scale.” The spectrum of relationships to human scale ranges from intimate to monumental. The components of a building with an intimate scale are often small and include details which break those components into smaller units. At the other end of the spectrum, monumental scale is used to present a feeling of grandeur, security, timelessness or spiritual well-being. Building types which commonly use the monumental scale to express these feelings are banks, churches and civic buildings. Landscape or hardscape elements can also bring human scale to a large building by introducing features such as a tree canopy, leaf textures, color and fragrance.



---

# Architectural, Design & Planning Terms

**Setback** The minimum horizontal distance between the lot or property line and the nearest front, side or rear line of the building (as the case may be), including porches or any covered projection thereof, excluding steps.

**Sill** The framing member that forms the lower side of an opening, such as a door sill. A window sill forms the lower, usually projecting, lip on the outside face of a window.

**Spalling** The process, usually caused by moisture being trapped inside bricks, whereby the face of the brick falls off due to extreme changes in temperature.

**Storefront** The traditional “main street” façade bounded by a structural pier on either side, the sidewalk on the bottom and the lower edge of the upper façade on top, typically dominated by retail display windows. The parts of the building that face the street and connect with the sidewalk

**Street Wall** The edges created by buildings and landscaping that enclose the street and create space. Sometimes called, “frontages.”

**Surface Materials** Can be used to create a texture for a building from the roughness of stone to the smoothness of marble or glass. Some materials, such as wood, may be either rough (such as wood shingles or re-sawn lumber) or smooth (such as clapboard siding).

**Texture** The concept of texture refers to variations in the exterior façade and may be described in terms of roughness of the surface material, the patterns inherent in the material or the patterns in which the material is placed. Texture and lack of texture influence the mass, scale and rhythm of a building. Texture also can add intimate scale to large buildings by the use of small detailed patterns, such as brick masonry.

**Transom** The horizontal division or cross-bar in a window. A window opening above a door.

**Trim** The decorative finish around a door or window; the architrave or decorative casing used around a door or window frame.

---

# Acknowledgments & Sources

## Sources

Many resources are available to help guide property owners on the care of old buildings and on planning work. Some of the materials used in the preparation of this document are listed in this section, and many of them should be available online or at your local library. Additional information and advice can be obtained from the agencies and organizations listed below.

### ORGANIZATIONS & AGENCIES

#### LOCAL:

**Tri-County Regional Planning Commission**  
112 Market Street #2  
Harrisburg, PA 17101  
(717) 234-2639  
<https://www.tcrpc-pa.org>

#### STATE:

**Pennsylvania State Historic Preservation Office (SHPO)**  
400 North Street, 2nd Floor, Harrisburg, PA  
[www.phmc.pa.gov/Preservation](http://www.phmc.pa.gov/Preservation)

#### NATIONAL:

**National Park Service**  
U.S. Department of the Interior  
Washington, D.C.  
[www2.cr.nps.gov/tps/index.htm](http://www2.cr.nps.gov/tps/index.htm)

**National Trust for Historic Preservation**  
1785 Massachusetts Avenue, N.W., Washington, D.C. 20036  
(202) 588-6000  
[www.nthp.org](http://www.nthp.org)

---

# Acknowledgments & Sources

## Publications

### MAGAZINES:

#### Old-House Journal

2 Main Street

Gloucester, Massachusetts 01930

(800) 234-3797

#### Traditional Building

69A Seventh Avenue

Brooklyn, New York 11217

(718) 636-0788

### BROCHURES:

Preservation Briefs *(These publications prepared by the National Park Service are available for purchase from the Superintendent of Documents and, in limited quantities, from the SC Department of Archives & History.)*

- #1 The Cleaning and Waterproof Coating of Masonry Buildings
- #2 Re-pointing Mortar Joints in Historic Masonry Buildings
- #3 Conserving Energy in Historic Buildings
- #4 Roofing for Historic Buildings
- #5 The Preservation of Historic Adobe Buildings
- #6 Dangers of Abrasive Cleaning to Historic Buildings
- #7 The Preservation of Historic Glazed Architectural Terra-Cotta
- #8 Aluminum and Vinyl Siding on Historic Buildings: The Appropriateness of Substitute Materials for Resurfacing Historic Wood Frame Buildings
- #9 The Repair of Historic Wooden Windows
- #10 Exterior Paint Problems on Historic Woodwork
- #11 Rehabilitating Historic Storefronts
- #12 The Preservation of Historic Pigmented Structural Glass (Vitrolite and Carrara Glass)
- #13 The Repair and Thermal Upgrading of Historic Steel Windows
- #14 New Exterior Additions to Historic Buildings: Preservation Concerns

---

# Acknowledgments & Sources

- #15 Preservation of Historic Concrete: Problems and General Approaches
- #16 The Use of Substitute Materials on Historic Building Exteriors
- #17 Architectural Character—Identifying the Visual Aspects of Historic Buildings as an Aid to Preserving Their Character
- #18 Rehabilitating Interiors of Historic Buildings
- #19 The Repair and Replacement of Historic Wooden Shingle Roofs
- #20 The Preservation of Historic Barns
- #21 Repairing Historic Flat Plaster—Walls and Ceilings
- #22 The Preservation and Repair of Historic Stucco
- #23 Preserving Historic Ornamental Plaster
- #24 Heating, Ventilating, and Cooling Historic Buildings: Problems and Recommended Approaches
- #25 The Preservation of Historic Signs
- #26 The Preservation and Repair of Historic Log Buildings
- #27 The Maintenance and Repair of Architectural Cast Iron
- #28 Painting Historic Interiors
- #29 The Repair, Replacement, and Maintenance of Historic Slate Roofs
- #30 The Preservation and Repair of Historic Clay Tile Roofs
- #31 Mothballing Historic Buildings
- #32 Making Historic Properties Accessible
- #33 The Preservation and Repair of Historic Stained and Leaded Glass
- #34 Applied Decoration for Historic Interiors: Preserving Historic Composition Ornament
- #35 Understanding Old Buildings: The Process of Architectural Investigation
- #36 Protecting Cultural Landscapes: Planning, Treatment and Management of Historic Landscapes
- #37 Appropriate Methods for Reducing Lead-Paint Hazards in Historic Housing
- #38 Removing Graffiti from Historic Masonry
- #39 Holding the Line: Controlling Unwanted Moisture in Historic Buildings
- #40 Preserving Historic Ceramic Tile Floors
- #41 The Seismic Retrofit of Historic Buildings: Keeping Preservation in the Forefront

---

# Acknowledgments & Sources

## Design Guidelines and Information from Other Locales

Anderson Notter Associates, Inc. and Historic Salem Incorporated. *The Salem Handbook: A Renovation Guide for Homeowners*. n.p.: Historic Salem Incorporated, 1977.

Frazier Associates. *City of Manassas Historic District Handbook*. 1990.

*German Village Society Guidelines*.

John Milner Associates. *The Beaufort Preservation Manual*. 1979.

LDR International, Inc. *City of Columbia, SC, City Center Design/Development Guidelines*. 1998.

*Material Treatment Guidelines for Rehabilitation in Savannah's Historic District*. 1990.

Pickart, Margaret M. M. *Gettysburg Design Guide: A Guide for Maintaining and Rehabilitating Buildings in the Gettysburg Historic District*. n.p.: Gettysburg Historic Architectural Review Board, 1997.

Sullivan, Charles, Woodford, Eileen, et. al. *Maintaining Your Old House in Cambridge*. Cambridge, Mass.: Cambridge Historical Commission, 1988.

## Books

### GENERAL:

Alexander, Christopher, Ishikawa, Sara, and Silverstein, Murray. *A Pattern Language: Towns, Buildings, Construction*. New York, Oxford University Press, 1977.

Heritage Preservation and National Park Service. *Caring for Your Historic House*. New York: Harry N. Abrams, 1998.

Kitchen, Judith L. *Caring for Your Old House: A Guide for Owners and Residents*. New York: John Wiley & Sons, 1991.

---

## Acknowledgments & Sources

Morton, W. Brown III, Hume, Gary L., Weeks, Kay D. and Jandl, H. Ward. *The Secretary of the Interior's Standards for Rehabilitation & Illustrated Guidelines for Rehabilitating Historic Buildings*. Washington, D.C.: U.S. Department of the Interior, 1992.

Poore, Patricia, ed. *The Old-House Journal Guide to Restoration*. New York: Dutton, 1992.

Rhode Island Historic Preservation Commission. *Easy Guide to Rehab Standards*. Providence, R.I.: Rhode Island Historic Preservation Commission, 1992.

State Historic Preservation Office, SC Dept. of Archives and History. *Manual for Owners of Historic Buildings*. 1995.

### **SPECIFIC ISSUES:**

Curtis, John O. *Moving Historic Buildings*. U.S. Department of the Interior, National Park Service, 1991 reprint.

New York Landmarks Conservancy. *Repairing Old and Historic Windows: A Manual for Architects and Homeowners*. Washington, D.C.: Preservation Press, 1992.

London, Mark. *Masonry: How to Care for Old and Historic Brick and Stone*. Washington, D.C.: Preservation Press, 1988.

Mandelker, Daniel R. and Ewald, William R. *Street Graphics and the Law*. Washington, D.C.: Planners Press, 1988.

---

## Acknowledgments & Sources

### BUILDING STYLES & TERMS:

Blumenson, John J.-G. *Identifying American Architecture: A Pictorial Guide to Styles and Terms, 1600-1945*. Nashville: American Association for State and Local History, 1977.

Harris, Cyril M., ed. *Historic Architecture Sourcebook*. New York: McGraw-Hill, 1977.

McAlester, Virginia & Lee. *A Field Guide to American Houses*. New York: Alfred A. Knoph, 1984.

Phillips, Steven J. *Old-House Dictionary: An Illustrated Guide to American Domestic Architecture (1600-1940)*. Lakewood, Colo.: American Source Books, c 1989; Washington, D.C.: Preservation Press, 1992.

Rifkind, Carole. *A Field Guide to American Architecture*. New York: New American Library, 1980.

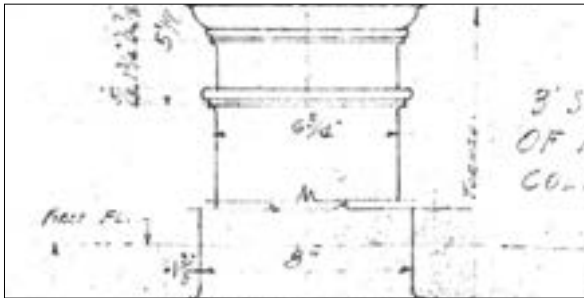

Portions of the residential section of these guidelines were developed by Margaret Marion of Aiken, SC. The authors of this document are grateful for her contribution.

# Perry County, PA

## Design Guidelines

Prepared for  
Perry County, Pennsylvania

Funded by  
Keystone Communities Grant



MAHAN RYKIEL  
LANDSCAPE ARCHITECTURE  
URBAN DESIGN & PLANNING

2307 Lincoln Street Columbia, SC 29201  
[www.communitydesignsolutions.com](http://www.communitydesignsolutions.com)  
803.240.9050